



# THREE POINT LINKAGE BOOMS PRAY



Hayes Spraying  
ABN 54 011 061 260  
1 Troy Drive  
PO Box 515  
GOONDIWINDI QLD 4390

P 07 4671 3092  
F 07 4671 3155  
E [sales@hayesspraying.com.au](mailto:sales@hayesspraying.com.au)



## CONTENTS

<b>WARRANTY POLICY</b>	<b>1</b>
<b>PRODUCT INFORMATION</b>	<b>2</b>
Shipping Information	2
Serial Number	2
Specifications	3
<b>SAFETY INSTRUCTIONS</b>	<b>4</b>
Operator Responsibilities	4
Safe Chemical Use	5
Safe Boomspray Operation	5
<b>LINKAGE OPERATION c</b>	<b>6</b>
Operating Speeds	6
Programming The Controller	6
Setting Up The Hypro Pump	7
Hooking Up The Linkage	8
Manual Folding – Folding Out / In	8
Hydraulic Folding – Folding Out / In & Wing Tilt Adjustment	11
Filling	13
Filter Maintenance	14
Hydraulic Boom Height Levelling System	16
<b>GENERAL MAINTENANCE</b>	<b>17</b>
<b>TROUBLESHOOTING</b>	<b>19</b>
TeeJet 844E	19
Speed Sensor	19
Flowmeter	20
Reg Valve	20
Electrical Faults	20
Hypro Pump	21
Hydraulic System	21
<b>SPRAYING TECHNIQUE</b>	<b>23</b>
Mixing Chemical	23
Decontamination	23
Calibration	23
<b>PARTS ASSEMBLY DRAWINGS</b>	<b>24</b>
Electrics – Wiring	24
Electrical Diagram	28
Three Point Linkage Mounted Pump & Fill Point	29
Electric Ball Valve Assembly	30
Pressure Filter Assembly	31
Sundry Parts	32
Plumbing Diagram	33
<b>USING THE LINKAGE WITH FRONT TANK ASSEMBLY</b>	<b>34</b>
Maintenance	34
Filling the tank using twin tank plumbing	34
Hose Kit & Plumbing For Front Tank	35
Filtration System	39
<b>APPENDIX</b>	<b>41</b>
Valve Identification	41
Regulation Valve Identification	42
TeeJet Nozzle Capacity Guide	43
Parts List – On/Off Valve, Reg Valve, Flowmeter	44
Hypro Manual	49

## **WARRANTY POLICY**

Hayes Spraying Pty Ltd, warrants to the original purchaser, that each new Hayes Spraying Pty Ltd boomspray, part or accessory will be free from defect in material or workmanship for twelve (12) months after the date of delivery.

During the warranty period, the Dealer or Hayes Spraying Pty Ltd shall repair or replace, at Hayes Spraying option, without charge for parts and labour any part of the Hayes Spraying Pty Ltd product which fails because of defects in parts or workmanship.

Pumps, engines, controllers, tyres and hoses are all warranted directly by the original manufacturer, pending that manufacturer's warranty approval.

This warranty does not cover damage resulting from misuse, neglect, alterations, or normal wear and tear.

In no event shall the authorised dealer or Hayes Spraying Pty Ltd be liable for downtime expenses, loss of chemical, loss of machine use or other incidental damages.

### **Exclusions**

At the discretion of Hayes Spraying Pty Ltd, the defective part must be returned to Hayes Spraying Pty Ltd at the owners cost.

Time for wash-down, transportation costs or insurance costs for sprayers are not warranted.

Travel and communication are not covered by warranty.

## PRODUCT INFORMATION

### SHIPPING INFORMATION *(Different models will vary)*

#### Manual Fold 24m

Height on legs: 2.45m  
Width folded: 4.3m approx.  
Length folded: 4.6m approx.  
Weight empty: 1260 kg approx.

#### Hydraulic Fold 24m

Height on legs: 2.45m  
Width folded: 3.9m approx.  
Length folded: 7.5m approx.  
Weight empty: 1750 kg approx.

#### Hydraulic Fold 18m

Same as above  
Weight Empty: 1300 kg approx.

## SERIAL NUMBERS



Serial Number Plate  
Located on left hand side of rocker bar

## SPECIFICATIONS

### Tanks

1000L, 1200L, 1500L, 2000L polyethylene tanks with hinged lid and filling strainer.

### Pump

Hypro hydraulic driven centrifugal pump (variable between 10 LPM - 450LPM)

Available as either boom mounted or tractor mounted

- 1 ½" Cast Series 9303C 9303C-HM4C
- 1 ½" Stainless Steel Series 9303S 9303S-HM4C

### Filtration

3 point filtration

- 18 mesh tank basket
- 2 pressure filters (80 mesh)
- nozzle filters (50 mesh)

### Booms

Manual Fold: 16m, 18m, 24m, 27m

Hydraulic Fold: 18m, 24m, 27m

Booms finished in chemical resistant two pack paint.

Booms are fitted with TeeJet non drip bodies and quick release nozzle caps.

Booms fitted with individual hydraulic boom tilt, shock dampened, breakaway end sections, self-levelling, and hydraulic accumulators for boom suspension.

### Chassis

Fully welded box steel construction, with park / unhooking legs painted with chemical resistant two pack paint.

### Hydraulic Boom Levelling System (Optional)

The boom height levelling system has been specially designed to provide improved ground following particularly in contoured terrain.

### Spray Controller Options

Options include TeeJet 744A-3 Manual Control or TeeJet 844E or 854E, fully automatic rate controllers.

Adapter harnesses for Greenstar or Trimble Ez-boom Controllers are available.

## SAFETY INSTRUCTIONS

### OPERATOR RESPONSIBILITIES

- Read and understand the operator's manual before using the equipment. All other operators of the sprayer must also read and understand the operator manual.
- Lower the boom fully or put safety pins in place if the boom needs to be raised.
- Take notice of the safety warning labels on the boomspray.
- Keep fresh water tank full with clean water only.
- Read and follow the chemical labels
- Local laws may require operators to be licensed
- Pressure test the sprayer with water before use
- Wear protective clothing
- Rinse, wash and depressurize equipment after use and before servicing or storage
- Never repair or service the equipment while it is operating.
- Disconnect power before servicing and or welding
- Do not eat drink or smoke while spraying or working with spraying equipment.
- Wash and change clothes after spraying
- Wash tools if they have been contaminated
- If poisoned seek medical advice immediately. Identify the chemicals being used
- Keep children away from spray equipment at all times
- Do not enter the spray tank
- Do not go under any equipment unless properly secured
- Be aware of power lines at all times
- Operators must not be under the influence of drugs or alcohol while operating spraying equipment.



Take notice of warning labels and always replace warning decals when damaged

## SAFE CHEMICAL USE

### The hazard

All agricultural chemicals and pesticides are biologically active. They can be dangerous to all living organisms including: humans, fish, birds, bees and domestic animals and plants.

### Method of pesticide entry

- Oral – by drinking and splashing into the mouth or by smoking or eating with contaminated hands. Cleaning nozzles by blowing through them with your mouth.
- Inhalation - by nose or mouth of spray drift and mist
- Dermal – absorption through the skin particularly with raw chemical or through cuts and abrasions or while perspiring.

### Decontamination

- Change out of protective clothing after spraying and wash separately
- Wash thoroughly before eating or drinking
- Keep fresh water tank on sprayer full with clean water
- Replace respirator filters regularly
- Clean sprayer regularly & fix leaks
- Ensure cab filters are adequate for the job
- Always use the recommended type of protection clothing and equipment

## SAFE BOOMSPRAY OPERATION

- Always read your sprayer manual before operating.
- Make sure all other operators have read the sprayers manuals and are suitably trained in the use of the equipment and chemicals being used.
- Always wear protective clothing.
- Inspect sprayer for faults, leaks, and cracks to avoid contamination.
- Personnel only associated with the spraying operation who are suitably trained, should be in the immediate area of operation.
- Bystanders must be a safe distance away from the sprayer while operating and in the upwind direction.
- Contamination is the responsibility of the operator.
- While spraying be aware of the width of the machine. Particularly while turning or moving around obstacles.
- Boom tips move much faster while turning and may cause injury to equipment or bystanders if careless.
- Before operation check that booms are unfolded and locked into position correctly.
- Check that boom support legs are lifted and pinned in the operation position
- Spray at speeds suitable to the ground conditions for safe operation and extended sprayer life.
- Avoid sudden turns or constant direction changes at high speed.
- Do not ride on the boomspray.



## LINKAGE OPERATION

### OPERATING SPEEDS

Incorrect operating speeds will void warranty, and compromise the life of your boomspray

<b>Operating speeds</b>	<b>Good conditions</b>	<b>Rough conditions</b>
Manual Fold	18kmph	16kmph
Hydraulic Fold	18kmph	16kmph

*NOTE: Operating speeds may need to be further reduced by 20-40% when crossing contour banks, wash outs, extremely rough conditions and when turning at the end of the field.*

*When using auto steer systems the boom should be aligned with the run prior to engaging the auto steer.*

## PROGRAMMING THE CONTROLLER

See the TeeJet Controller Manual and Quick Reference Guide included.

## SETTING UP THE HYPRO PUMP

### ***Hypro pumps cannot be run dry or the seal will be damaged***

For the best care and ensuring a long life of your Hypro pump please follow the directions listed. Please note that Hypro pump life will be greatly reduced and higher maintenance required if operated at excessive pressures.

1. The Hypro pump return line hydraulic hose should be connected to a free flow return, not the breakaway couplings. "Tank" is written on the return port of the Hypro pump. The pressure line hydraulic hose is connected to the breakaway couplings and is identified by spiral guard on it.
2. Ensure filters are clean.
3. Set main bypass/ agitation ball valve at pump for the chemical you are using. E.g. approx. ¼ turn open for glyphosate. This valve should never be fully open or fully closed whilst spraying.
4. Set hydraulics to slow / low flow.
5. Turn spray controller on (if fitted) and open regulator valve fully, by pressing console to manual operation and pressing the + key for 7 seconds. Turn all boom sections and master switch on.
6. Engage Hypro pump hydraulics and increase hydraulic flow until desired maximum spray pressure is achieved.  
Do not exceed 5 bar pressure when spray nozzles are on or spraying.  
Do not exceed 6 bar pressure when the spray nozzles are off.
7. Low pressure warning alarm set up (if installed).  
Close the regulator valve by pressing the – key on the controller (spraying pressure will drop) until 12 – 15 psi is displayed on gauge. Next adjust the pressure switch (below & behind pressure gauge) with small screw driver until alarm beeps at approximately 1 bar pressure (12 – 15 psi). Make sure master switch and boom section switches are turned on, check alarm setting by cycling pressure up and down using the + & - keys on the controller in the manual position.
8. The alarm serves to notify the operator that the tank level is low and the pump is starting to suck air.
9. Please note Hypro pumps cannot be run dry or the mechanical seal will be damaged. Shut pump down immediately when pressure drops below 1 bar. Centrifugal pumps need fluid to pump effectively and cannot pump air.
10. Bypass screw is required to be screwed in entirely so pump has the full flow oil when used with closed centre hydraulic systems.

## HOOKING UP THE LINKAGE



1. Have bystanders stand well away while backing the tractor into the three point linkage attachment points.
2. Lift linkage sprayer off the ground slightly and lock the linkage into place.
3. Connect hydraulic hoses for the sprayer.
4. If connecting hydraulic hoses for the pump be sure to put the return line into the free flow return or dump port of the tractor (may vary from tractor to tractor).
5. Connect electrical leads for the controller and

## MANUAL FOLDING - FOLDING OUT / IN BOOMS

### FOLDING OUT

1. Raise the tip lift slightly on each boom to take the weight of the boom off the rests.

**Do not over-tighten the chains when pinned as the booms will bend.**



2. From the rear of the sprayer remove the lynch pins and push the boom towards the front of the tractor until the boom locks into position at the top hinge on the swing arm.



3. Remove the lynch pin located at the top of the boom approx. 1m from the centre section.



4. Swing the boom arm forward until it is in line with the first boom section and locks into place



5. Unclip breakaway and swing around to the front automatically



6. Use tip lift to level booms ready for spraying. When booms are level there should be 40 – 50mm travel left in the hydraulic ram.



7. Pull out self-levelling pin and lock out of the way

## FOLDING IN

1. Put self-level pin in the locked position
2. Bring booms down from tilted into a level position.
3. Fold breakaway tip back in and clip into place.
4. Release locking catch and swing boom arm back & refit lynch pin at top of boom.
5. Release the lock at the top hinge.



6. Swing the boom back onto the linkage frame to lock with the lynch pin. The tip lift may have to be adjusted for the boom to fit into the locking position
7. Lower the boom tips slightly to put weight on the boom supports. The chains will slacken slightly.





## HYDRAULIC FOLD - FOLDING OUT / IN BOOMS & WING TILT ADJUSTMENT

### BOOM MUST BE STATIONARY WHEN FOLDING

#### FOLDING OUT

##### STOP MOVING!

After folding out pin should be out ready for spraying.

Before folding in for travelling, pin should be in.



1. **STOP MOVING!** First move the TILT RAISE switch for the side you are unfolding upwards to raise the booms off the carrier frame – make sure the bottom of the boom clears the top of the frame.
2. Then move the INNER FOLD switch for the side you are unfolding downwards until the section is unfolded. Do the same for the OUTER FOLD.
3. Unlock the self-level pin.

Some hydraulic fold models require the breakaway tip to be folded manually

#### FOLDING IN

1. **STOP MOVING!** Lock the self-level pin into the locked position.
2. Move the OUTER FOLD switch upwards until the section is folded in.
3. Move the INNER FOLD switch upwards making sure the bottom of the boom clears the cradle using the TILT RAISE switch until the section is folded in.
4. Use the TILT RAISE switch to lower the boom onto the cradle and into the travelling position.

#### NOTE:

If the booms have been tilted all the way up, you may find that the booms won't drop immediately. To enable the booms to drop, hold the TILT switch on for 5 seconds or until booms drop.

## FOLDING OPENING & CLOSING SPEED ADJUSTMENT

Hydraulic flow should be regulated so a constant fold or unfold is performed without the need for “pulsing” the controls, because the oil flow is too quick.

Adjust the flow of oil at the tractor first to fine tune opening and closing speeds. Tractors with an oil flow rate of 100L/min should be set at approx. 30%.

Needle valves are placed on each port of the cylinder to allow slow and constant folding and unfolding. The needle valves have been factory set, to open and close at a safe speed.

If a fold function is operating too quickly, the flow can be adjusted by the needle valves located at each hydraulic cylinder.

The speed is controlled by the oil leaving the cylinder, not the oil entering.

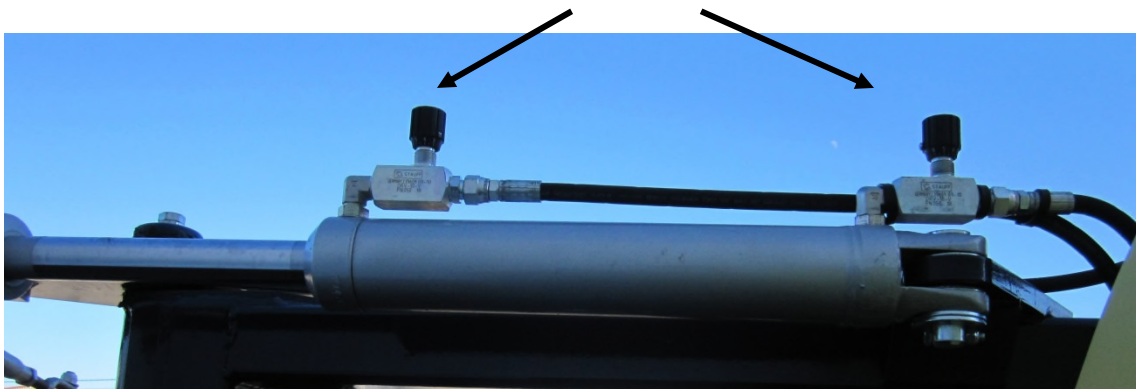

## WING TILT ADJUSTMENT FOR HYDRAULIC FOLD

The adjusting screw on the accumulator mount block is used to control the speed of the tilt hydraulic cylinder when lowering only.

Adjustment can be made with a 5/32 hex key.

To Slow Down – screw clockwise

To Speed Up – screw anticlockwise



## FILLING

### Filling

Filling the sprayer tank with chemical and water will depend on what system you have. Options include:

- Fill through linkage sprayer
- Fill through front tank mounted on the tractor
- Fill through chemical hopper or vat

### Fill through linkage sprayer tank

Hook 1 ½ camlock hose to fill point at the rear of the sprayer and turn on tap A and B.

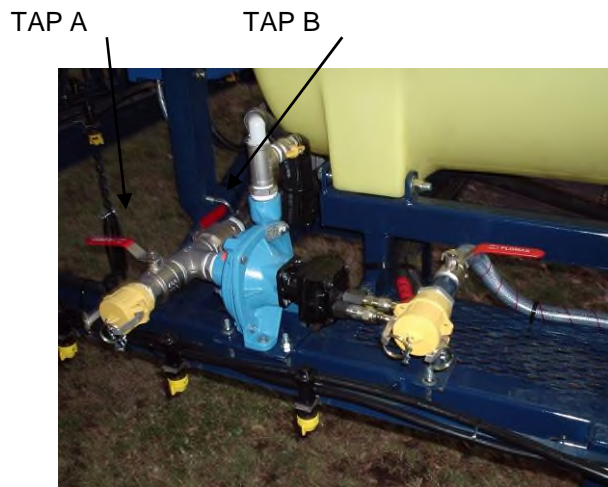

### Filling via front mounted tank

1. Connect 1 ½ camlock hose to fill point and turn on tap A.
2. Check that taps B and C are in the on position and that taps D and E are in the off position. This will fill the front tank.
3. To fill the rear tank turn on D and E and turn off B and C.

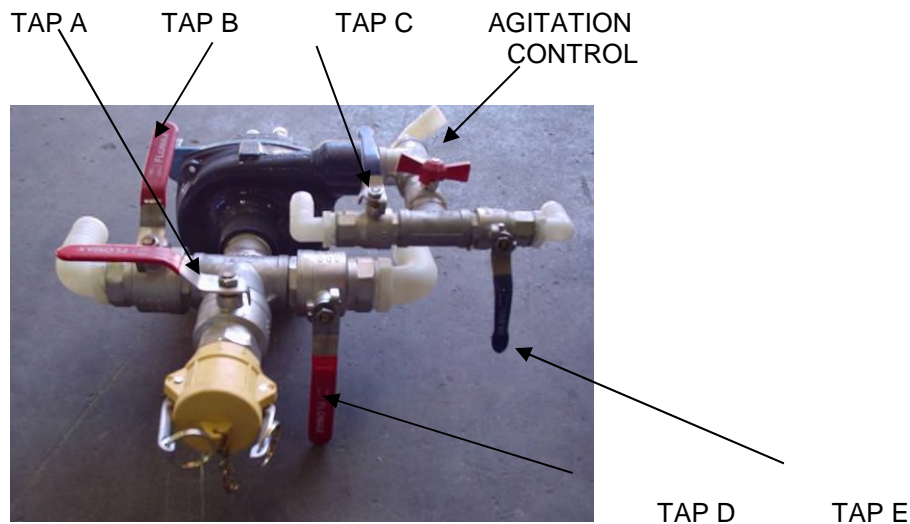



## FILTER MAINTENANCE

Filter maintenance is a critical part of your sprayers operation. The number and type of filters may dependent on sprayer type. They will include:

Tank filter basket located in the top of the tank (18 mesh)



Pressure filters located between the pump and spray lines. (80 mesh)

In line nozzle filters located in the nozzle bodies (50 mesh)



Filters require regular cleaning. Regularity will depend on the quality of water being used and type of chemical being used

As a guide:

- Pressure filters should be cleaned once a day
- Nozzle filters should be cleaned once a week

### The cleaning process

1. Completely stop all sprayer functions
2. Release all pressure from the spray lines
3. Unscrew ( clockwise ) bottom filter bowl and remove
4. Use a toothbrush to clean filter under running water
5. Reseat filter into filter bowl and screw back onto filter body
6. Take care not to cross thread or damage the o ring while re- assembling



## HYDRAULIC BOOM HEIGHT LEVELLING SYSTEM (optional)



The boom height levelling system has been specially designed to provide improved ground following particularly in contoured terrain.

The system is engaged via a dual electric/hydraulic control panel mounted in the cabin (LED illuminate when engaged).

In operation, the levelling system senses via boom mounted jockey wheels when a load is apparent and according takes weight off the boom tilt hydraulic cylinders hence making the boom become weightless (approx. 20Kg). Jockey wheel pressure is recommended at 20 psi.

When engaged, the system will automatically lower to the present height avoiding the need to make constant adjustments.

*Note:* When turning ensure jockey wheels do not make contact with the ground. This prevents a sideways screwing effect of the wheel and any consequent boom stress.

### ADJUSTMENT

The pressure adjusting screw will require some minimal adjustment. If the boom tends to lay back on the chains when operating or falls too quickly to the ground when the control panel is engaged, the boom will be too heavy on the ground.



To adjust the boom height levelling system:

1. Have the tractor hydraulic oil at operating temperature.
2. Have the levelling control panel switches turned on
3. Loosen the lock nut on the block
4. Using the 5/32 hex key, turn clockwise until the boom lifts slightly off the ground
5. Turn anticlockwise until the boom slowly lowers to the ground
6. Lock up the lock nuts
7. Test the weight of the boom by manually lifting. You should feel approximately 20kg of weight to lift.

The boom will fall quicker when spray rig is moving. Do not worry if it only falls very slowly when stationary.

**WARNING:** Major damage will be incurred if:

- Using jockey wheels without the leveller being engaged.
- You allow the wheel to run too heavily on the ground (see adjustment above).
- You don't slow down as required when crossing contours & on rough terrain.

The automatic levelling system will only work properly with tractors that have a genuine pressure and flow compensated closed centre, variable flow systems with flow rates in excess of 100L/min. E.g. JD6000, 7000 & 8000 series & Case Magnum range.

## GENERAL MAINTENANCE

### SERVICING

There are 7 grease nipples on a manual fold and 15 on a hydraulic fold that require grease every 10 hrs

Grease Point  
First Fold x 2 (each side)

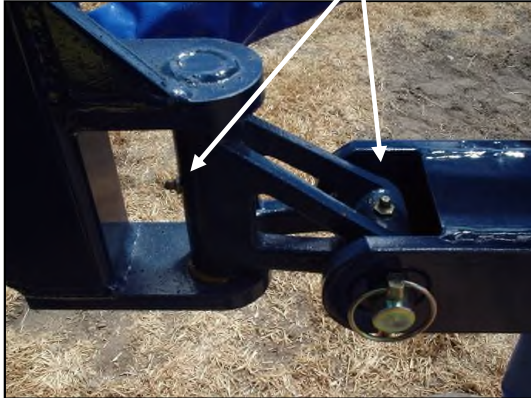

Grease Point  
Second Fold x 4 (each side)



Manual Fold Swing arm  
(1 each side)



Hyd. Fold Swing arm  
(1 each side)



Remote access Grease Point  
for Self-Level Pivot x 1

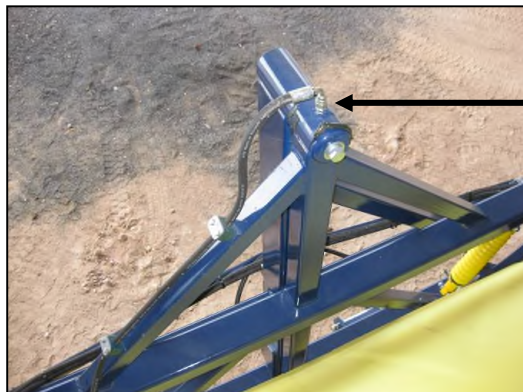

**AT THE END OF SPRAYING**

Always flush the booms with water at the end of every day. Note when spraying liquid fertilisers, check for phosphoric acid content. If left in the pump, it can corrode the pump body and galvanized fittings in as little time as a week. Roundup can corrode a cast pump body in less than two years.

**DAILY**

1. Connect fill hose
2. Close tank suction hose and agitation / bypass
3. Pump water through spray lines
4. Spray lines can be cleaned with chemical mix still in the tank

**END OF SPRAYING SESSION**

1. Drain any remaining spray mixture from the tank at the appropriate place
2. Fill spray tank with 200l of water
3. Open agitation line fully
4. Set the controller to manual
5. Spray 100L of water out of the boom with the end taps open or remove end nozzles
6. Note that if the water flow is low the regulator valve may be closed. Open the valve manually by holding the + key down on the controller
7. Close boom taps and spray 100L of water out of the nozzles.

**LONG TERM STORAGE**

1. Flush as described previously
2. Drain all water from the system
3. Drain water from the pump.
4. Fill pump with a 50 % mix of water and anti-freeze. Take particular care not to have any air in the pump. Note that in frost prone areas- frost can freeze water in the pump and crack the housing
5. Clean the outside of the sprayer with appropriate tank cleaner



## TROUBLESHOOTING

### CONTROLLER – TeeJet 844E

Understanding the sprayer controller and its functions can help greatly when diagnosing problems.

The controller controls the rate based on the target application set before spraying such as L/Ha and then whilst spraying received input information from the speed sensor and the flow meter.

For example the target application rate may be 50 l/ha using 11002 nozzles (110 degree size 2 nozzles) The controller calculates the target rate by receiving speed inputs and L/min inputs.

If the calculation is done and the rate per ha is too high, the controller closes the pressure regulating valve to restrict the flow to the nozzles and therefore lowers the application rate. If the calculation is done and the rate is too low the controller will open the pressure regulating valve.

The controller will also let you know when the spraying speed is too low or too high for the controller to regulate using the desired nozzle and application rate.

Most problems can be found quickly by asking the following questions:

#### Does the monitor record?

- Speed
- Hectares
- L/minute
- Does the sprayer spray in Manual
- Can you manually adjust the pressure and flow
- Are all the fuses good

### SPEED SENSOR

#### If you have no speed

- Check speed sensor cable for cuts, breaks etc
- Check that the sensor is plugged in correctly
- Check that the magnets are in place
- Can you see the LED light in the end of the sensor when the magnet passes.
- Check that the sensor is the correct distance away from the magnets. 10-20mm



#### If you have no hectares

- See above for speed sensor
- Check that the width is correctly set in the controller

## FLOWMETER

### If you have no L/min (turbine flashing)

1. Check that the pump is pumping liquid
2. Check the flow meter cable for cuts, breaks etc.
3. Check that the flow meter is not stuck or restricted. Check flow is still showing. IF NOT, hold PRO button in & you should show a constant flow in the lower right hand corner of screen.  
If a blockage occurs in the flow meter, a flashing symbol will appear at the top of the screen, flush the flow meter with clean water, the flow meter should spin freely when you blow through it.

### Tank Output Discrepancies - Flowmeter

If the volume displayed on controller is 5% too high (compared to actual volume sprayed), then increase the flow meter calibration number by 5%.

If the volume displayed on controller is 5% too low (compared with actual volume sprayed) then decrease the flow meter calibration number by 5%.

## REG VALVE

### If you cannot adjust the flow manually

1. Check that power is getting to the pressure regulating valve
2. Check that the pressure regulating valve is cycling by either listening to it open and close, or watching it open or close if your valve has a yellow butterfly. To cycle, put controller onto manual mode & press the + or – button (on 844e controller). If you hear movement this means the valve is operating correctly.
3. Apply separate 12VDC source to valve (isolates valve from controller/cables) & reverse polarity of Red & Black wires.

### Sprayer stops spraying while in Auto Mode

- Flashing Turbine symbol – Flowmeter has stalled
- Sometimes when the Reg valve closes too far maybe even complete shut-off, this can cause the flow meter to stall.
- Press MANUAL mode depress the + key for 3 seconds. Return to AUTO mode.

### No Regulation in Auto Mode

- Check Speed Sensor – See Speed Sensors
- Regulating Valve Malfunction

### If flow won't adjust in Auto Mode

- if you are only using 1 or 2 sections & operating slowly, you may need to operate in manual, as some flow meters cannot operate below 10L/min

## ELECTRICAL FAULTS

### The console switches itself off in 20 seconds and “clicks”

- There is a dead short in the electrical leads
- Disconnect the sensor cables one by one to isolate the short.

### Other Electrical Faults

- check 15 amp wedge fuse at battery & check 60 amp maxi fuse at battery
- ball valves have an internal resettable fuse - disconnect power for 20 seconds.
- check wiring harness
- check pins in deutsch connectors have not been pushed out.
- If you have had low voltage or had a power spike, the console can reset to default settings, (change back to the same as in the mini manual.

## HYPRO PUMP

The pump and hydraulic motor are both manufactured by Hypro.

**Important:** when connecting the hydraulic hoses to the tractor the return line must be connected to a free flow return – not the breakaway coupling.

For start-up, tuning, and troubleshooting refer to the “setting up the Hypro pump “section, and the “Hypro” section.

## HYDRAULIC SYSTEM

The hydraulic spool system on the boomspray has been fitted to suit your tractor depending on whether you have an open or closed system. The majority of systems use the closed system.



The electric solenoid spool valves are Rexroth brand with a J 3 top.  
 On a closed centre system the diagram on the side of the spool would show A-B-T.  
 On an open system the diagram would show P-T.  
 Between the hydraulic block and the solenoid valve there is a pilot operated check valve to prevent cylinder creep.

Closed centre A-B-T

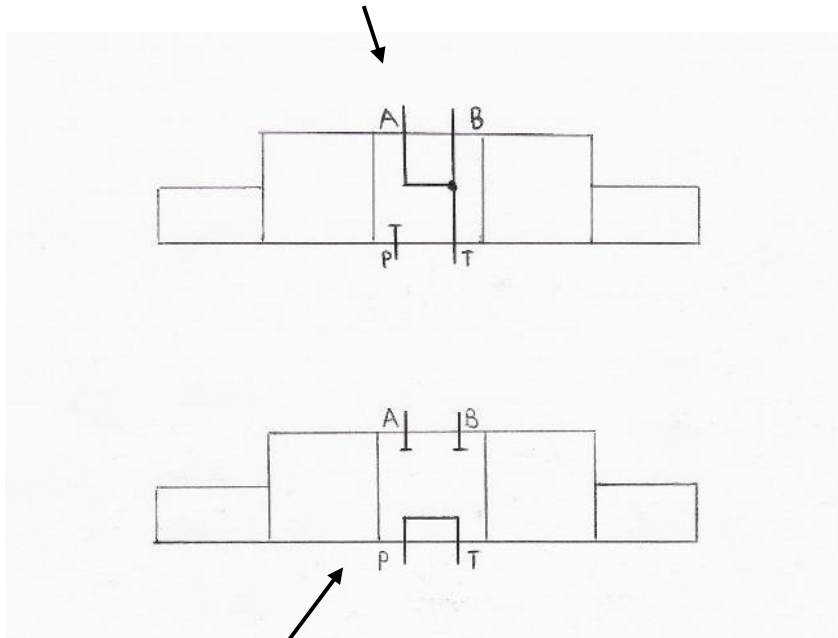

Open centre P-T

The spool valves are a maintenance free unit.



If a hydraulic function does not work, check the following:

1. The wiring plugs on the solenoid valves (Herchman plugs) can be swapped from one valve to another to determine if a hydraulic fault is electrical or hydraulic. Take note of the hydraulic function the test plug is taken from so that the correct in cab control switch is used.
2. Is there power getting to the Herchman plug. You can check by using a multimeter.
3. Does the solenoid 'click' when activated? As the power requirement is low for the solenoid to work, the 'click' is not loud.
4. If the solenoid is faulty, it can be swapped with another, as shown in the diagram below.
5. The hydraulic function can be activated manually by pushing a small Philips head screwdriver into either end of the spool valve, opening the valve to override.

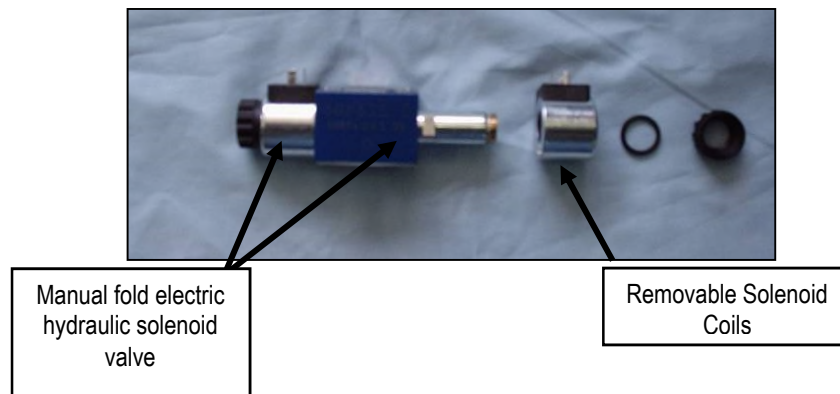

Hydraulic hoses are coded by coloured spiral wrap. The red spiral wrap indicates the pressure hose, when inserting into the tractor breakaway port. Hoses are either 3/8 or 1/2, fitted with BSP fittings.

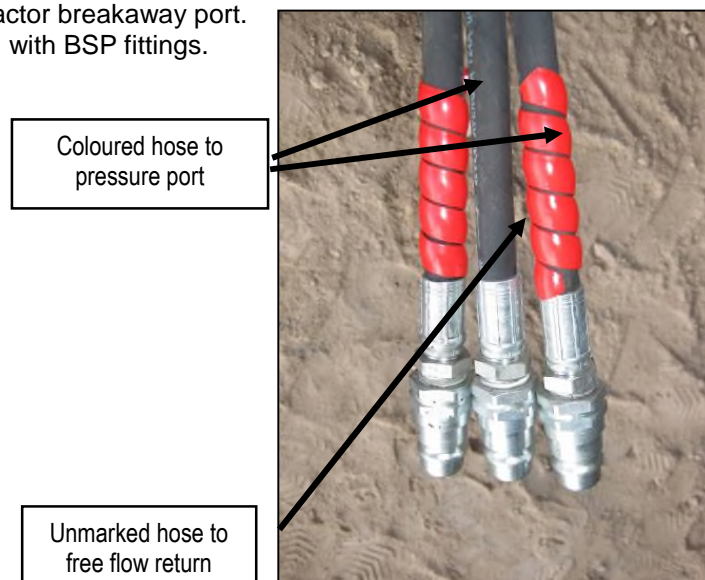

## SPRAYING TECHNIQUE

### MIXING CHEMICAL

When mixing chemicals, always check and follow the label and agronomists recommendations. If unsure, mix a small amount of concentrate in a jug to observe any reaction between the chemical mix.

For example, when mixing Glyphosphate and 24-D concentrates together, a chemical reaction can occur causing the chemicals to go hard.

When mixing chemical fill the tank half full with water before adding chemical.

Add the chemical separately, rinsing the measuring jug each time before adding the next chemical.

If using a vat, follow the same procedure, rinsing the vat each time before adding the next chemical.

### DECONTAMINATION

When changing from one chemical group to another, or from spraying one type of crop to another it may be necessary to decontaminate the tank, boom, and lines.

For example, when changing from spraying fallow ground to spraying over a crop, or from spraying a narrow leaf crop to a broad leaf crop.

1. Flush all spray lines, agitation lines, delivery hoses, tank, jugs, and vat with clean water.
2. Flush again with the recommended cleaner. Different chemicals require different cleaning agents to neutralize the active chemical. Check the chemical label or agronomist to use the correct cleaning agent, and time for penetration.
3. Flush out the cleaning agent with clean water.
4. Be sure to carry out all rinsing and cleaning, on jugs vats, delivery pumps and hoses

### CALIBRATION

For manual controlled sprayers, follow the calibration set out in the TeeJet Catalogue.

For automatic controllers, refer to the TeeJet 844E controller manual.

Also in this manual.

- **Nozzle Selection Guide**

For choosing which **type of nozzle** best suits your application. Overview includes nozzle size, pressure chart, spray angle, material.

- **Nozzle Bodies, Caps, Tip Strainers & Line Strainers**

Overview of spare parts & ordering information.

- **Nozzle Droplet Size Chart**

Demonstrates droplet size of particular nozzles at given pressures.

## PART ASSEMBLY DRAWINGS

### ELECTRICS

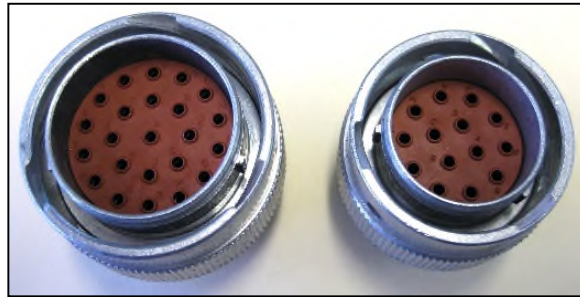

23 Pin Deutsch Plug

14 Pin Deutsch Plug

All linkage boomsprays from July 2010 have a 23 pin deutsch plug fitted for the controls. Earlier models may have a 23 pin OR a 14 pin plug. Customers with existing boomsprays fitted with the 14 pin plug that need to be interchangeable with tractors are urged to change to the new 23 pin plug style.

### 23 PIN DEUTSCH PLUG FOR 844E CONTROLLER

PIN	WIRE	FUNCTION
A	White	Switch 1
B	Brown	Switch 2
C	Green	Switch 3
D	Yellow	Switch 4
E	Grey	Switch 5
F	Green 4mm	Negative for Valves
G	Brown	Regulator Valve
H	White	Regulator Valve
J	Red 4mm	Positive for Valves
K	White / Red	Flow Signal
L	Brown	Flow Power
M	Green	Flow Earth
N	White / Green	Wheel Signal
O	Brown	Wheel Power
P	Green	Wheel Earth
Q	Black	Pressure Power
R	White	Pressure Signal
S	White	Blank
T	Purple	L Fence line / Switch 9
U	Orange	R Fence line / Switch 10
V	Pink	Switch 6
W	Blue	Switch 7
X	Red / Yellow	Switch 8

NOTE – 844-E is standard with 5 switch only. Pin T to X may not have wires fitted in harness.

**23 PIN DEUTSCH PLUG FOR 844E CONTROLLER WITH FOAM MARKER**

<b>PIN</b>	<b>WIRE</b>	<b>FUNCTION</b>
A	White	Switch 1
B	Brown	Switch 2
C	Green	Switch 3
D	Yellow	Switch 4
E	Grey	Switch 5
F	Green 4mm	Negative for Valves
G	Brown	Regulator Valve
H	White	Regulator Valve
J	Red 4mm	Positive for Valves
K	White / Red	Flow Signal
L	Brown	Flow Power
M	Green	Flow Earth
N	White / Green	Wheel Signal
O	Brown	Wheel Power
P	Green	Wheel Earth
Q	Black	Pressure Power
R	White	Pressure Signal
S	White	Foam Right
T	Green	Foam Compressor 1
U	Yellow	Foam Left
V	Red	Foam Power
W	Brown	Foam Compressor 2
X	Yellow	

**37 PIN AMP CONNECTOR FOR GREENSTAR 2**

<b>PIN</b>	<b>WIRE</b>	<b>FUNCTION</b>
1	Green 4mm	Valve Ground
4	White	Section 1
5	Brown	Section 2
6	Green	Section 3
7	Yellow	Section 4
8	Grey	Section 5
9	Pink	Section 6
10	Blue	Section 7
11	Red / Yellow	Section 8
12	Purple	Left Fence line – 9
13	Orange	Right Fence line – 10
15	White	Reg Valve
16	Brown	Reg Valve
21	Green	Flowmeter Shield
28	White / Red	Flowmeter #1 Signal
36	Red 4mm +	Valve Power
37	Brown +	Flowmeter +

**MAIN CONNECTOR AMP P/N 206037-1 TRIMBLE 16 PIN**

<b>PIN</b>	<b>WIRE</b>	<b>FUNCTION</b>
1	Green 4mm	GND
2	Brown 3mm	Boom 2
3	Brown 3mm	INC/DEC Reg Valve (Open)
4	White 3mm	INC/DEC Reg Valve (Close)
5	Green 3mm	Boom 3
6	White 3mm	Boom 1
7	Yellow 3mm	Boom 4
8	Grey 3mm	Boom 5
9	Pink 3mm	Boom 6
10		
11	Green 3mm	Flow Earth
12	Brown 3mm	Flow Power +
13	White / Red 3mm	Flow Signal
14		
15	Blue 3mm	Boom 7
16	Red 4mm	Positive +

**SECONDARY CONNECTOR AMP P/N 206044-1 TRIMBLE 14 PIN**

<b>PIN</b>	<b>WIRE</b>	<b>FUNCTION</b>
1	Red / Yellow 3mm	Boom 8
2	Purple 3mm	Boom 9
3	Orange 3mm	Boom 10

**OLD - 14 PIN DEUTSCH PLUG FOR 844E CONTROLLER WITH FOAM MARKER**

PIN	WIRE	FUNCTION
A	White	Switch 1
B	Brown	Switch 2
C	Green	Switch 3
D	Yellow	Switch 4
E	Grey	Switch 5
F	Green 4mm	Negative for Valves
G		
H		
J	Red 4mm	Power for Valves
K	White	Foam Right
L	Green	Foam Compressor 1
M	Yellow	Foam Left
N	Red	Foam Power
P	Brown	Foam Compressor 2

**OLD - 14 PIN DEUTSCH PLUG FOR 844E CONTROLLER WITH REG VALVE & FLOWMETER ON BOOM**

PIN	WIRE	FUNCTION
A	White	Switch 1
B	Brown	Switch 2
C	Green	Switch 3
D	Yellow	Switch 4
E	Grey	Switch 5
F	Green 4mm	Negative for Valves
G	Brown	Regulator Power
H	White	Regulator Power
J	Red 4mm	Power for Valves
K	White / Red	Flow Signal
L	Red	Flow Power
M	Black	Flow Earth
N		
P		

**14 PIN DEUTSCH PLUG FOR ELECTRIC / HYDRAULIC CONTROLS – HYD FOLDING ONLY**

PIN	WIRE	FUNCTION
A	Purple	Left tilt up
B	Dark brown	Left tilt down
C	White / Red	Right tilt up
D	White / Blue	Right tilt down
E	Grey	Left inner fold out
F	Orange	Left inner fold in
G	Blue	Right inner fold out
H	Red	Right inner fold in
J	Green	Left outer fold out
K	Yellow	Left outer fold in
L	White / Brown	Right outer fold out
M	White	Right outer fold in
N	Black or Red (power)	(-) Earth  (+) where connected to power pack solenoid, (where applicable).
O	Black	(-) Earth

## ELECTRICAL DIAGRAM

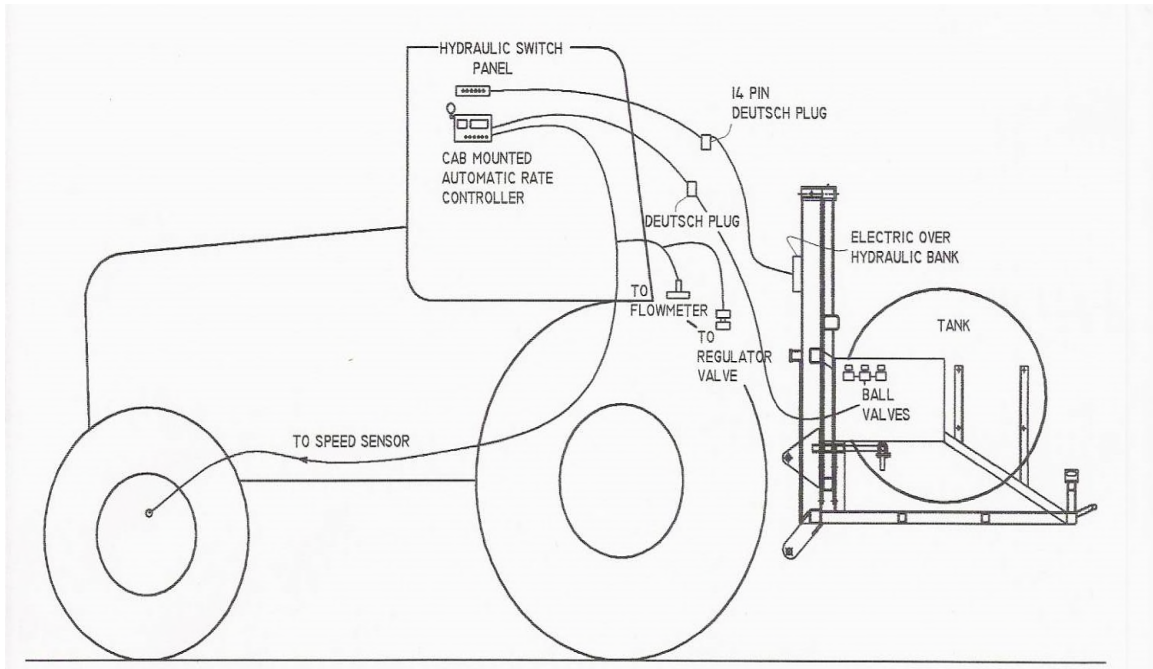



**THREE POINT LINKAGE MOUNTED PUMP & FILL POINT**

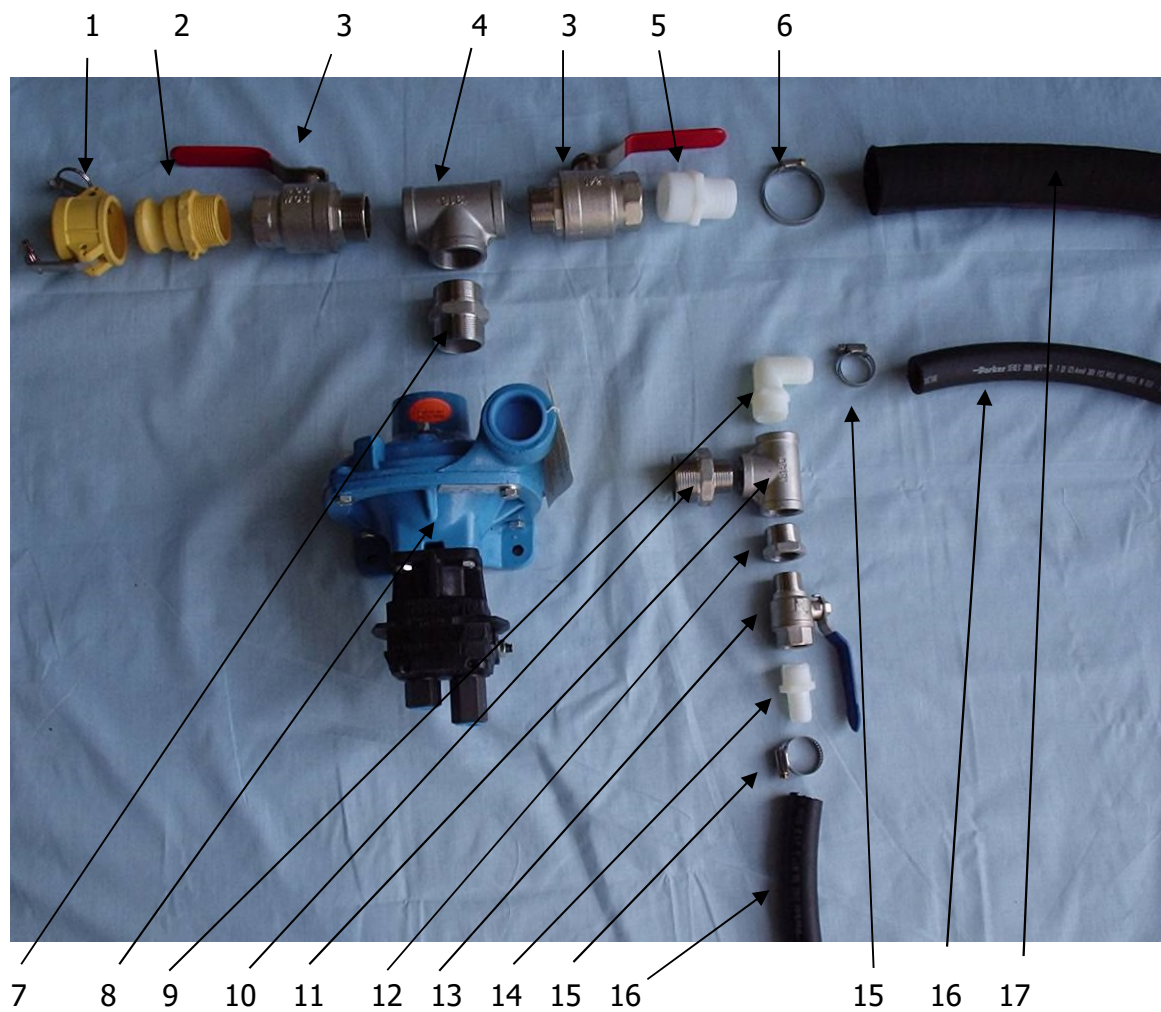

- |    |                |                                   |
|----|----------------|-----------------------------------|
| 1  | NY – 40DC      | 1 ½" camlock cap                  |
| 2  | NY – 40F       | 1 ½" male camlock male bsp        |
| 3  | BV – 38MF      | 1 ½" ball valve m/f nickel plated |
| 4  | SF – SS3508    | 1 ½" tee s/steel                  |
| 5  | NF – A112      | 1 ½" x 1 ½" hose barb nylon       |
| 6  | HC – BZ62028   | 1 ½" clamp                        |
| 7  | SF – SS2708    | 1 ½" nipple s/steel               |
| 8  | HP – 9303C-HM4 | Hypro pump and hydraulic motor    |
| 9  | NF – EL1034    | 1"m x ¾" elbow nylon              |
| 10 | SF – SS7311    | 1 ¼" x 1" reducing nipple s/steel |
| 11 | SF – SS3506    | 1" tee s/steel                    |
| 12 | SF – SS2412    | 1" x ¾" reducing bush s/steel     |
| 13 | BV – 20MF      | ¾" ball valve f/f nickel plated   |
| 14 | NF – A3434     | ¾" m x ¾" nylon hose barb         |
| 15 | HC – BZ62012   | ¾" clamp                          |
| 16 | HO – MPT20BL   | ¾" pressure hose                  |
| 17 | HO – 72161502  | 1 ½" suction / pressure hose      |

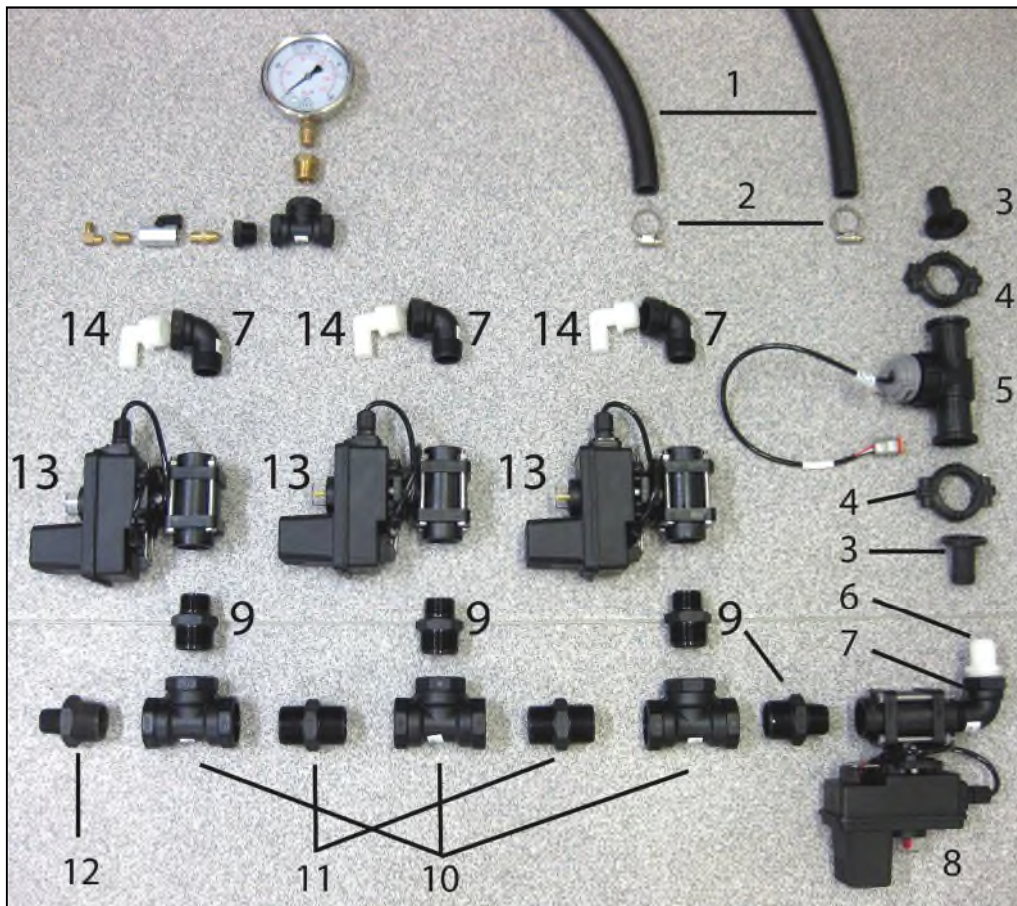

**ELECTRIC BALL VALVE ASSEMBLY (with boom mounted flowmeter)**

**Electric Ball Valve Assembly Parts**

1	HO – MPT20BL	3/4" pressure hose black
2	HC – BZ62012	3/4" hose clamp
<u>Flowmeter Assembly</u>		
3	SS - CP45504-PP	1" hose barb
	SS - CP45505-PP	1 1/4" hose barb
4	SS – 46070	flange connector/clamp
5	SS – 57-10100	801 1" flowmeter
<u>Misc.</u>		
6	NF – A1010	1" male x 1" hoesetail nylon
	NF – A11434	1 1/4" male x 1" hose barb elbow nylon
7	BP – SMFE25	1" male x 1" female elbow black poly
8	SS – B344BRL24S	1" s/systems regulating valve (std)
	SS – B344BRL25S	1 1/4" s/systems regulating valve
9	BP – SRHN3225	1" x 1 1/4" reducing nipple black poly
10	BP – ST32	1 1/4" tee black poly
11	BP – SHN32	1 1/4" nipple black poly
12	BP – SRHN3220	1 1/4" x 3/4" reducing nipple black poly
13	SS – B344BEC-24-C	1" s/systems elec. ball valve (std)
14	NF – EL1034	1" male x 3/4" hoesetail nylon

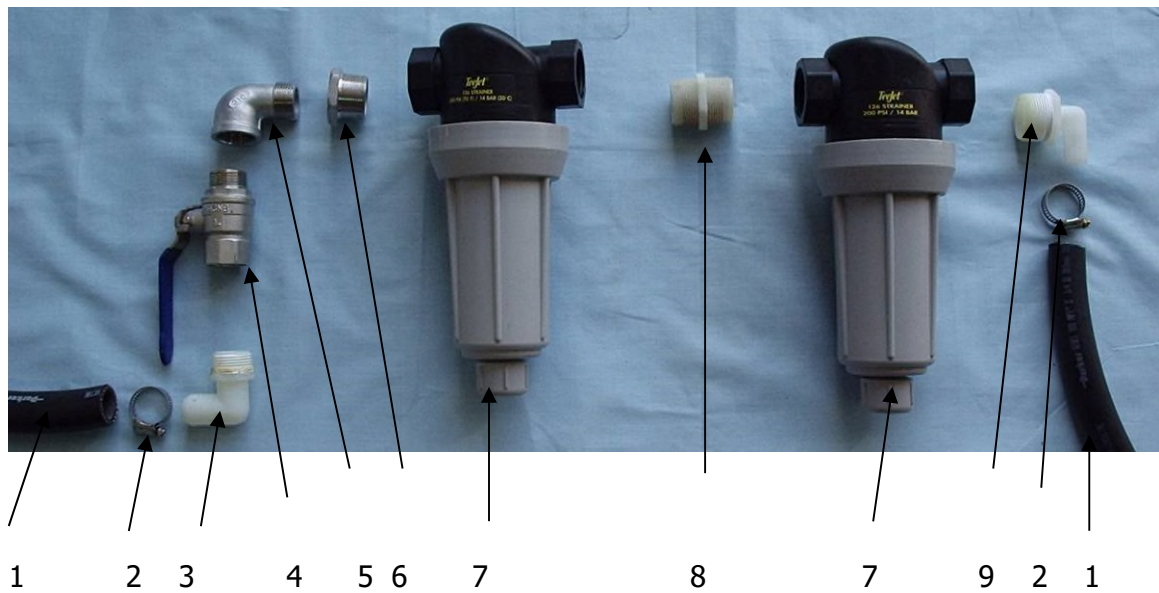
**PRESSURE FILTER ASSEMBLY**



- |    |                   |                                 |
|----|-------------------|---------------------------------|
| 1  | HO – MPT25BL      | 1" pressure hose                |
| 2  | HC – BZ62012      | 1" clamp                        |
| 3  | NF – EL1010       | 1" x1 hose barb elbow nylon     |
| 4  | BV – 25MF         | 1" ball valve m/f nickel        |
| 5  | SF – SS2511       | 1" x 1 m/f elbow s/steel        |
| 6  | SF – SS2415       | 1"x 1 ¼" reducing bush s/steel  |
| 7  | SS – AAB126-5-80  | 1 ¼" spraying systems filter    |
| 8  | BP – SHN32        | 1 ¼" nipple black poly          |
| 9  | NF – EL11434      | 1 ¼" x ¾" hose barb elbow nylon |
| 10 | BS – FILTERASSY-2 | Complete twin filter            |



**SUNDRY PARTS**

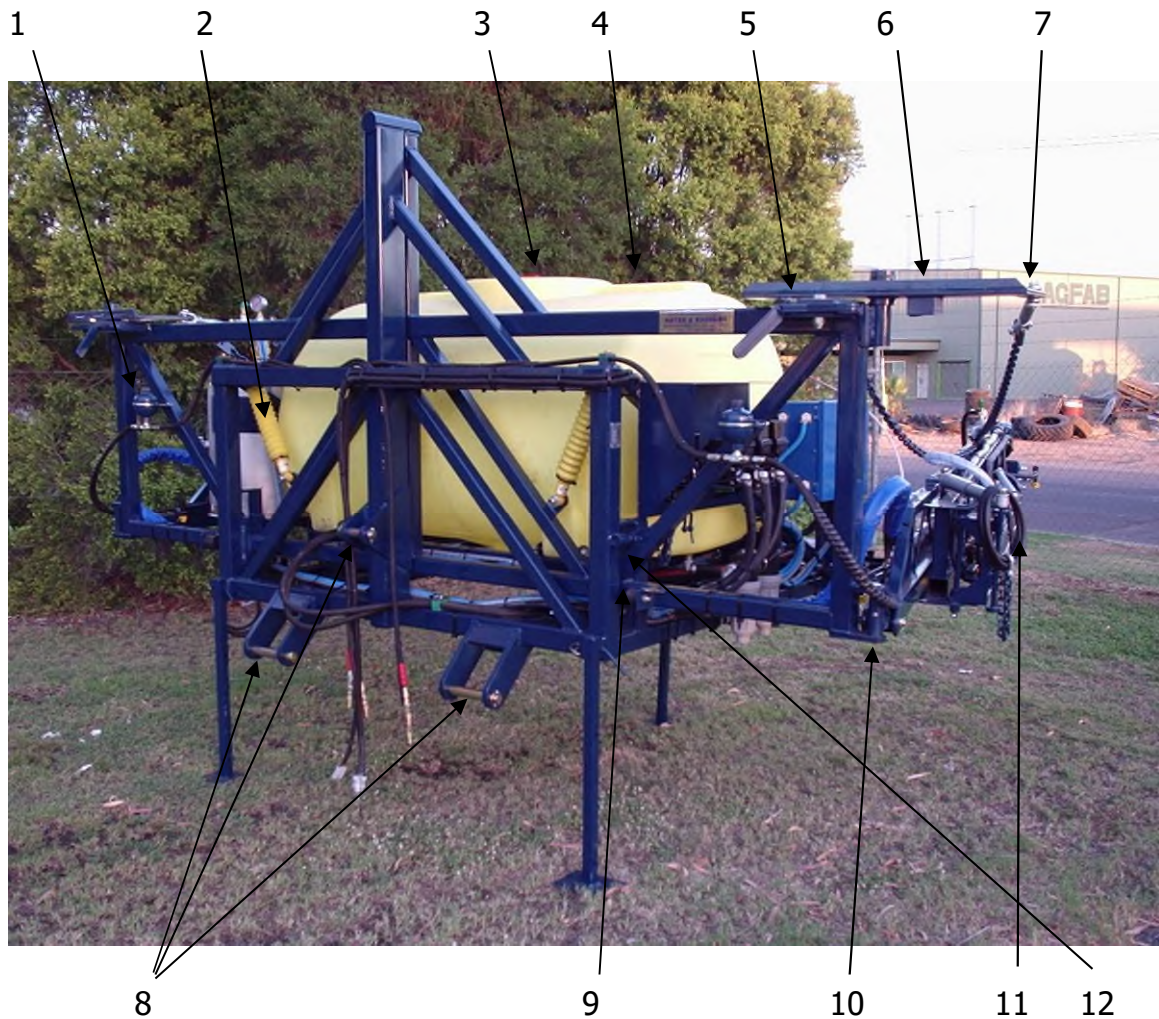

- |    |                   |                               |
|----|-------------------|-------------------------------|
| 1  | HY – SB0210-.32E1 | 2 X HYD ACCUMULATOR           |
| 2  | BS – 1366-2       | 2 X SHOCK ABSORBERS           |
| 3  | AR – 356060       | TANK LID                      |
|    | AR – 300126       | MESH BASKET                   |
| 4  | PT – ST1000LP     |                               |
|    | PT – ST1200LP     |                               |
|    | PT – ST1500LP     | POLY SPRAY TANK               |
| 5  | ST – HBP-06       | 2 X MAIN BOOM CATCH           |
| 6  | ST – HBP-07       | TOP SWING ARM                 |
| 7  | BS – TURNBUCKLE   | 4 X TURNBUCKLE                |
| 8  | BS – PIN1         | TOP LINKAGE PIN 32 X 155MM    |
|    | BS – PIN2         | BOTTOM LINKAGE PIN 36 X 250MM |
| 9  | BS – R – STOP     | 2 X ROCKING BAR BUMP STOP     |
| 10 | ST – HBP-26       | LOWER SWIVEL / HINGE          |
| 11 | BS – RR-658       | RUBBER RING                   |
| 12 | BS – NWP1         | 4 X NYLON WEAR PLATES         |
|    | ST – HBP-6        | 2 X MIDDLE BOOM CATCH         |
|    | BS – MGW-C20HD    | 20L FRESH WATER TANK          |
|    | BOOM – J/WHEEL-01 | JOCKEY WHEELS                 |
|    | BA – DNB-10       | 10MM SNAPHOOK                 |
|    | BA – B3           | 5/16 LYNCH PIN                |

\*Since 2013 Hayes Spraying have been supplying tanks made by Global Rotomoulding

**PLUMBING DIAGRAM**

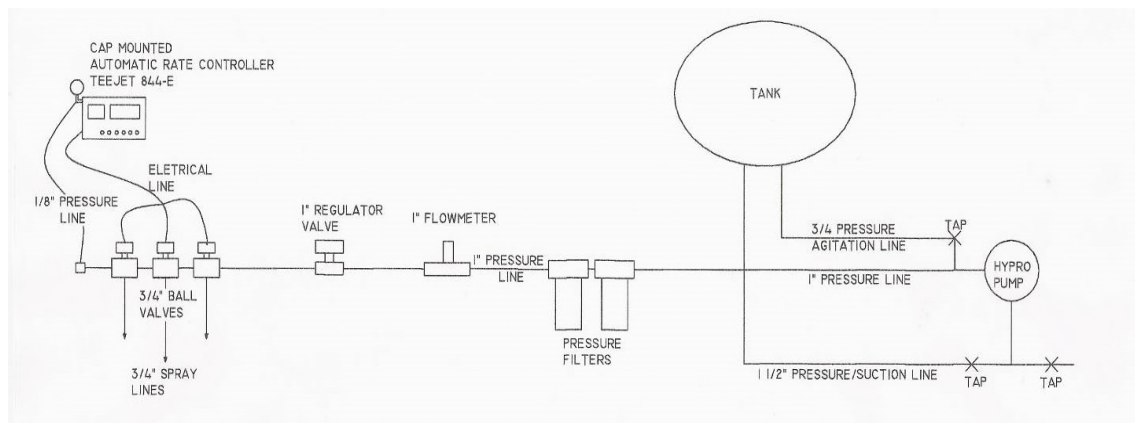
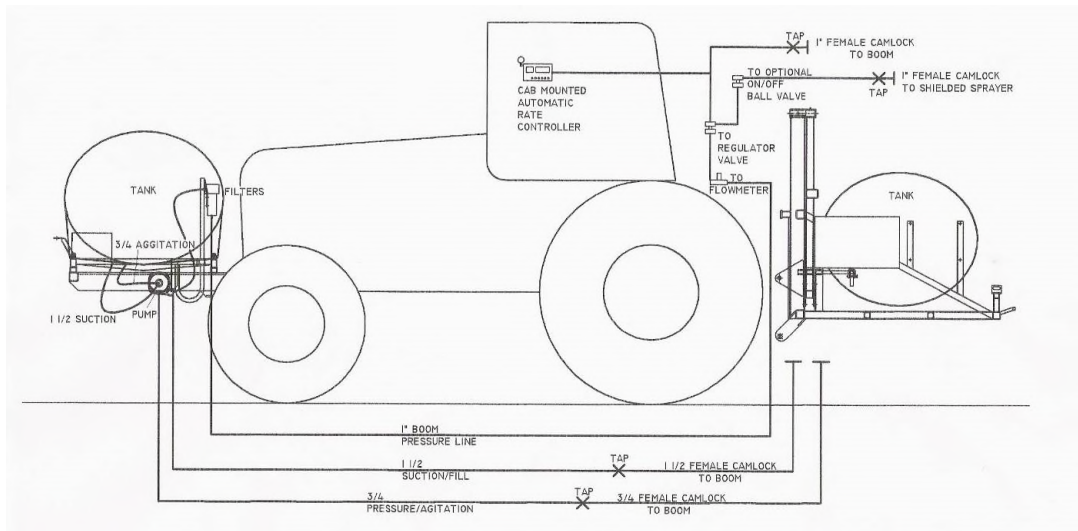

## USING THE LINKAGE WITH FRONT TANK ASSEMBLY

Hayes Spraying Front Tank Assemblies in most cases will replace a front weight kit for your tractor.

While not in use as a chemical tank, it is advisable to half fill the tank with water to gain the best performance and ride from your tractor.

Please refer to your tractor manual for recommended weights to place on the front of the tractor. When using the front tank to spray in tandem with a rear tank, you need to **empty the front tank last**.

This will avoid the tractor becoming tail heavy.

### MAINTENANCE

Check the chassis bolts that mount the frame to the tractor after the first 50 hours.

Check every 500 after. If replacing chassis bolts, ensure the bolts are no less than 10.9 grade.

### FILLING THE TANK USING TWIN TANK PLUMBING

1. Connect the 1.5" fill hose to the fill point and turn on Tap A -
2. Fill the front tank - Tap B & C are open and that Taps D & E are shut.
3. Fill the rear tank – Tap D & E are open and Taps B & C are shut.
4. When full close Tap A.
5. Leave Tap D & E open to spray rear tank out first.

Following are 2 diagrams with different views of the plumbing.

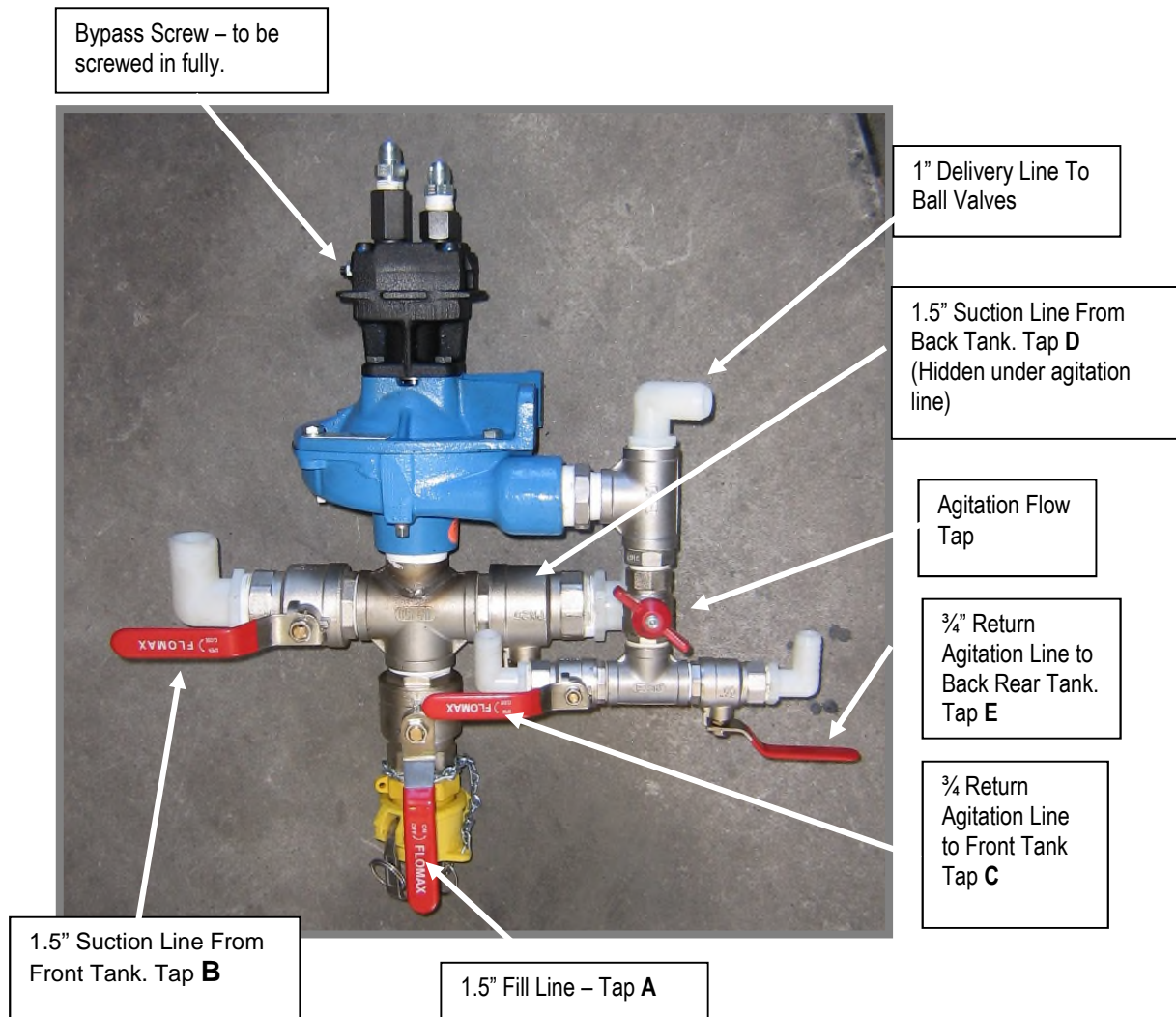



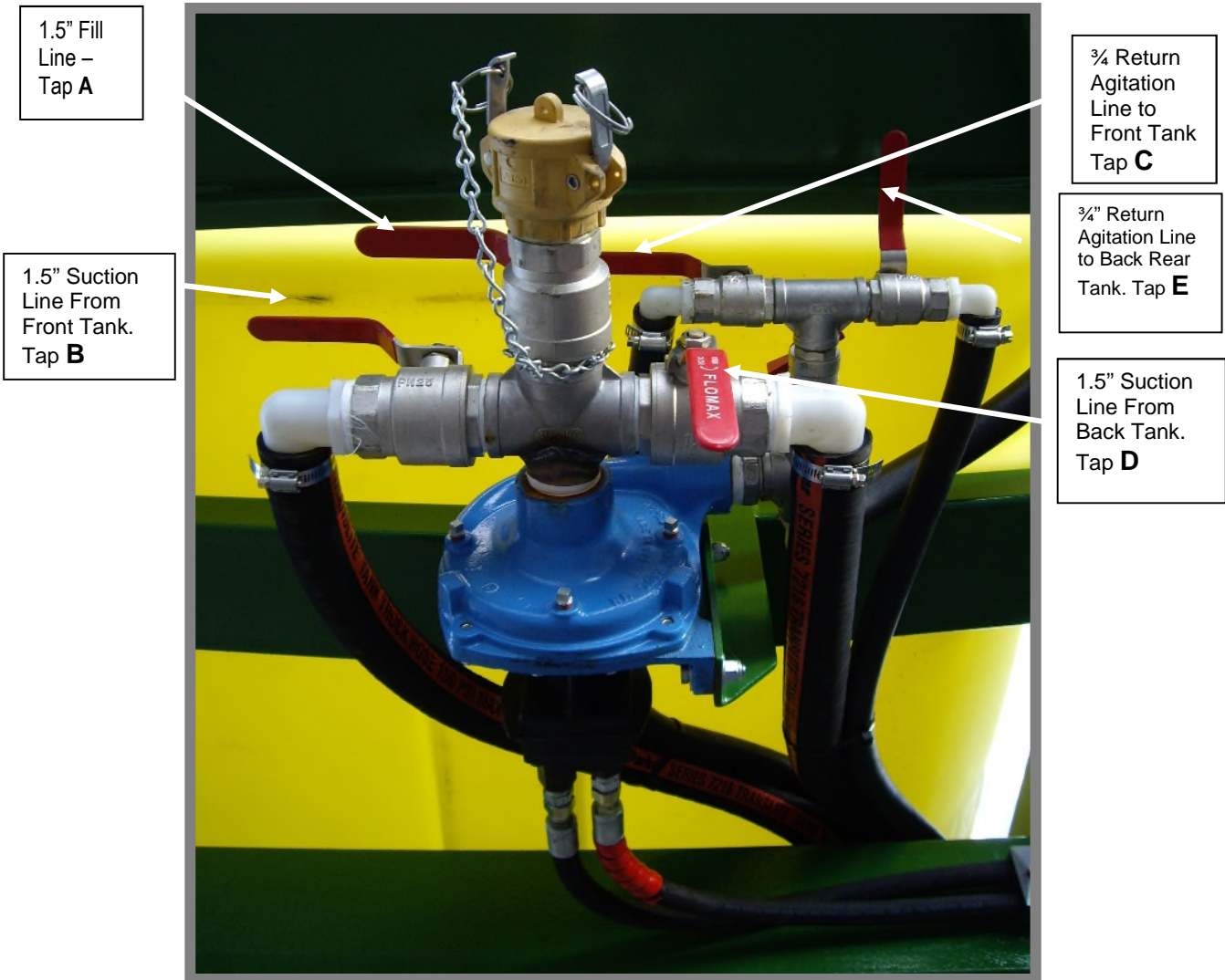

1.5" Fill Line – Tap **A**

3/4" Return Agitation Line to Front Tank Tap **C**

1.5" Suction Line From Front Tank. Tap **B**

3/4" Return Agitation Line to Back Rear Tank. Tap **E**

1.5" Suction Line From Back Tank. Tap **D**

**HOSE KIT AND PLUMBING FOR FRONT TANK**

For all options, the hydraulic hoses are run along the left side of the tractor; to the remotes and oil dump at the rear.

## Twin Tank Plumbing

A single 1" pressure line is run along the left side of the tractor to the rear. This goes to the ball valve or regulator valve which is mounted on the tractor. The line goes from these valves to the boomspray.

There is an additional 1.5" suction / fill line and 3/4" pressure agitation line which is run along the right side of the tractor to the rear. This connects directly to an additional tank mounted on the boomspray. This feature enables the rear tank to be filled and pumped from the front.

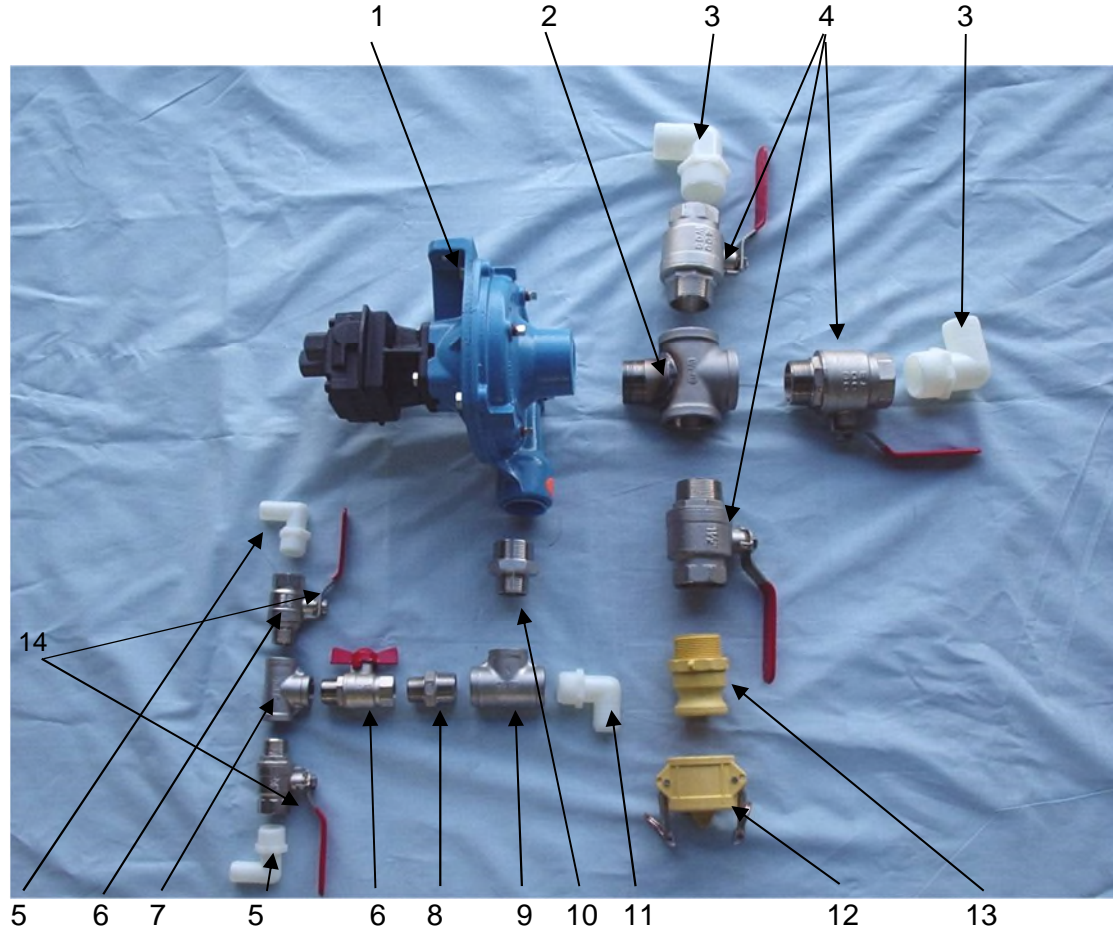

ITEM	PART NO.	DESCRIPTION
1	HP - 9303C-HM4	HYPRO PUMP AND HYDRAULIC MOTOR
2	SF - SS40CRMF	1 1/2 CROSS M/F S/STEEL
3	NF - EL112	1 1/2 X 1 1/2 HB ELBOW NYL
4	BV - 38MF	1 1/2 BALL VALVE M/F NICKEL
5	NF - EL3434	3/4 X 3/4 HB ELBOW NYL
6	BV - T20MF	3/4 BALL VALVE M/F NYL T-HANDLE
7	SF - SS305	3/4 TEE S/STEEL
8	SF - SS2412	1 X 3/4 REDUCING BUSH S/STEEL
9	SF - SS3506	1 TEE S/STEEL
10	SF - SS7311	1 1/4 X 1 REDUCING NIPPLE S/STEEL
11	NF - EL1010	1 X 1 ELBOW HB NYL
12	NY - 40DC	1 1/2 CAMLOCK CAP
13	NY - 40F	1 1/2 MALE CAMLOCK MALE BSP
14	BV - 20MF	3/4 BALL VALVE MF

## REAR TRACTOR PLUMBING

- **Regulating Valve** (Red Directional Marker) – used to control the pressure given differing speeds.
- **Single Ball Valve** or On/Off Valve (Yellow Directional Marker) – mounted on tractor for shielded spraying or planter use.

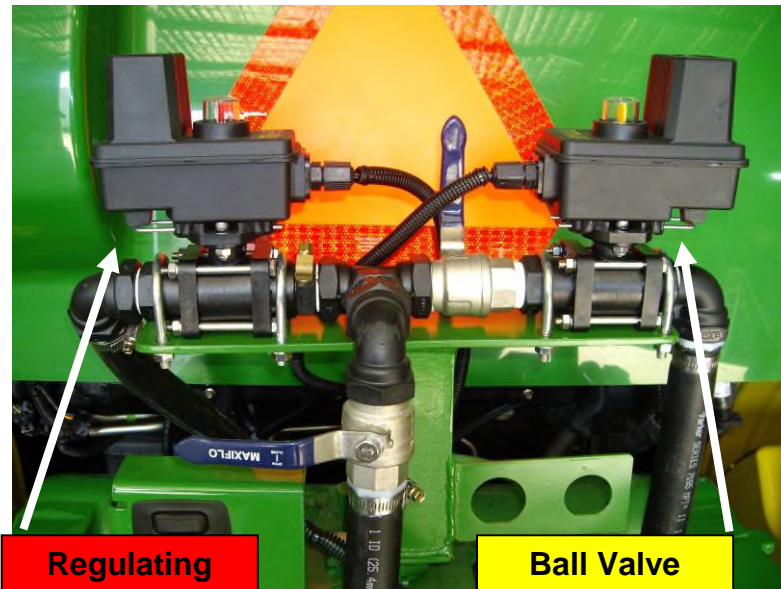

**Flow Meters** – measures litres per minute (LPM)



When using at TeeJet 844-E automatic controller, the flowmeter and regulator valve will normally be mounted on the rear of the tractor joined to the single 1" pressure line down the left side. The pressure line from the regulation valve connects to the sprayer.



### Shielded Sprayer's and Planters – Manual Control

A single ball valve can be mounted for manual control of shielded sprayers or planters. When used for shielded sprayers, the 1" pressure line is connected to the ball valve then to the sprayer. In this case no regulating valve is required to be fitted because hydraulic flow is used to control the pressure (in tractors where hydraulic flow can be controlled in cab).

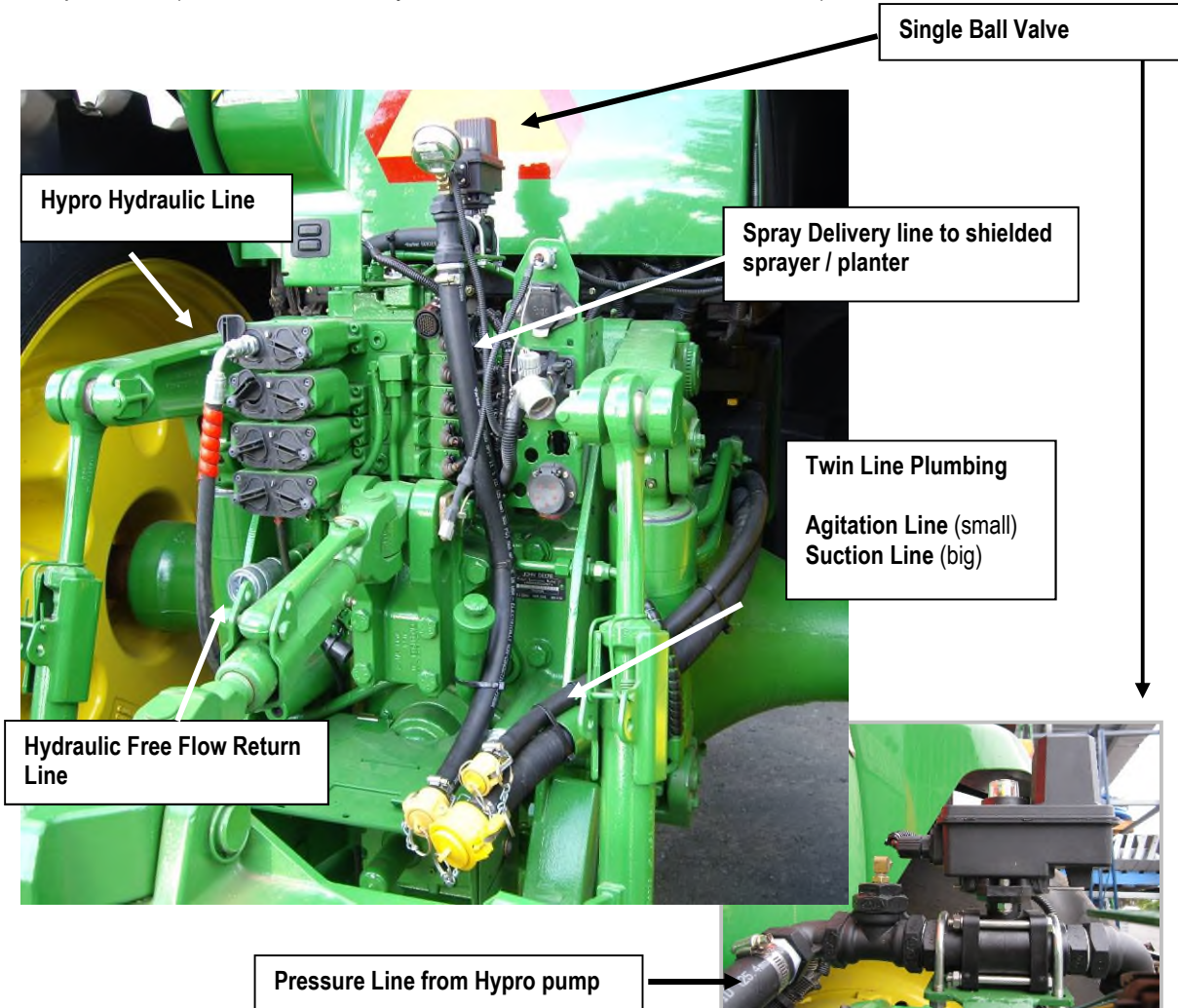

Pressure control is determined by oil flow which is controlled by the tractor hydraulic flow controls.

When using both the automatic and manual control valves together, the hose from the regulation valve is connected to the ball valve and then to the boomspray.

## FILTRATION SYSTEM

The filtration system is made up of 2 inline TeeJet strainer filters that are plumbed into the delivery line. The strainers come in various colours depicting the size screens. These screens should be cleaned regularly for optimum performance. If the filters are dirty it can affect the water rates and spray line pressures. We normally use 2 x blue 80 mesh screens for most applications.



### TeeJet

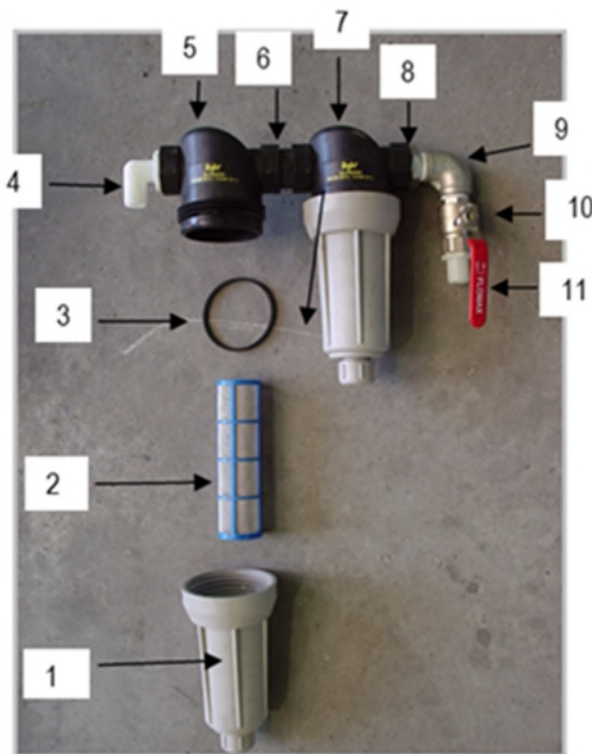

1. SS-CP48654-PP Strainer Bowl Grey 126 Series 1-1/4 BSP
2. SS-CP15941-4 Strainer Screen 124NY 80 Mesh (now yellow)
3. SS-CP48656-EPDM Gasket for 126 Filter 1-1/4 & 1-1/2
4. Nf-el1140 Nylon Elbow 1-1/4 BPSM x1 HB
5. SS-CPB63065-1-1 Strainer Head PP 126 Series 1-1/4 BSP
6. BP-SHN32 Poly Nipple BSP 1-1/4
7. SS-AAB126-5-80 Line Strainer 1-1/4 Complete
8. SF-SS2415 Bush Reducing S/Steel 1-1/4x1
9. SF-SS2511 Elbow S/Steel MF 1 BSP
10. BV-25MF Ball Valve Brass MF 1 BSP
11. NF-A1010 Nylon Fitting 1 Male x 1 HB

Banjo



1. BJ-MLST1150-80 Banjo Strainer 2 Flange T Body w/80MESH

2. BJ-FC200 Clamp 20 Series Banjo 2

3. BJ-150G Gasket 200 Series Banjo 2



- Dark Red – Size 16 Mesh
- Red – Size 30 Mesh
- Blue – Size 50 Mesh
- Yellow – Size 80 Mesh
- Green – Size 100 Mesh
- Brown – Size 120 Mesh

To keep the pump running at its optimum level the filters should be checked regularly. When using dirtier water sources they should be checked more frequently. To clean just run them under running water or in a bucket till the screens are clean.

## APPENDIX

### VALVE IDENTIFICATION



**TEEJET 344 Series 2-Way Electric Ball Valve**

Part No. SS-B344BEC-24-C

Circulation: 2005 onwards



**TEEJET 430 Series 2-Way Electric Ball Valve**

Part No. SS-430EC-2-D (Single Unit)

Part No. SS-435EC-2-D (5 Manifold)

Part No. SS-437EC-2-D (7 Manifold)

Circulation: 2010 onwards



**TEEJET 430 Series Flow Back Electric Ball Valve**

Part No. SS-435EC-3FB-D (5 Manifold)

Part No. SS-437EC-3FB-D (7 Manifold)

Circulation: 2010 onwards



**TEEJET 344 Series 2-Way Electric Ball Valve**

Black Box with 4 Screws. 3 Wires (Black, Red, White)

Part No. SS-AAB344AEC-2

Circulation: 1990 - 2005





**KZ 2-Way Electric Ball Valves**  
 Part No. KZ-NF2F-60A-M (1" 2-Way Valve)  
 Part No. KZ-T-12AM (1 Stack Manifold)  
 Part No. KZ-T-32AM (3 Stack Manifold)  
 Part No. KZ-T-52AM (5 Stack Manifold).

Circulation: Approx. 2007 - 2009



**TEEJET 144 Directo Valve 2-Way Solenoid Valve**

Part No. SS-AA144A-1-VI

Circulation: 1990 – 2000



**TEXAS INSTRUMENTS 1999 Series 2-Way Solenoid Valve**

Part No. TEX-1999A

Circulation: 1990 - 2000



**GOYEN 12V / 9W Solenoid Valve**

Part No. GOY-ST-6R

Circulation: 1990 - 2000

**REGULATING VALVE IDENTIFICATION**



**TEEJET 344 Series Electric Regulating Valve**

Part No. SS-B344BRL-24S-03CGS

Circulation: 2005 onwards



**TEEJET 344 Series Electric Regulating Valve**  
 Black Box with 4 Screws, 2 Wires (Black & Red)  
 Part No. SS-B38440-344AE-2RL-1

Circulation: 1990 - 2005

### TEEJET NOZZLE CAPACITY GUIDE

	BAR	1 Nozzle L/Min	L/ ha on 50cm Spacing										
			4 km/h	5 km/hr	6 km/hr	7 km/hr	8 km/hr	10 km/hr	12 km/hr	16 km/hr	18 km/hr	20 km/hr	25 km/hr
<b>Green 015</b>	1.5	0.42	126	101	84.0	72.0	63.0	50.4	42.0	31.5	28.0	25.2	20.2
	2.0	0.48	144	115	96.0	82.3	72.0	57.6	48.0	36.0	32.0	28.8	23.0
	2.5	0.54	162	130	108	92.6	81.0	64.8	54.0	40.5	36.0	32.4	25.9
	3.0	0.59	177	142	118	101	88.5	70.8	59.0	44.3	39.3	35.4	28.3
	4.0	0.68	204	163	136	117	102	81.6	68.0	51.0	45.3	40.8	32.6
	5.0	0.76	228	182	152	130	114	91.2	76.0	57.0	50.7	45.6	36.5
<b>Yellow 02</b>	1.5	0.56	168	134	112	96.0	84.0	67.2	56.0	42.0	37.3	33.6	26.9
	2.0	0.65	195	156	130	111	97.5	78.0	65.0	48.8	43.3	39.0	31.2
	2.5	0.72	216	173	144	123	108	86.4	72.0	54.0	48.0	43.2	34.6
	3.0	0.79	237	190	158	135	119	94.8	79.0	59.3	52.7	47.4	37.9
	4.0	0.91	273	218	182	156	137	109	91.0	68.3	60.7	54.6	43.7
	5.0	1.02	306	245	204	175	153	122	102	76.5	68.0	61.2	49.0
<b>Purple 025</b>	1.5	0.70	210	168	140	120	105	84.0	70.0	52.5	46.7	42.0	33.6
	2.0	0.81	243	194	162	139	122	97.2	81.0	60.8	54.0	48.6	38.9
	2.5	0.90	270	216	180	154	135	108	90.0	67.5	60.0	54.0	43.2
	3.0	0.99	297	238	198	170	149	119	99.0	74.3	66.0	59.4	47.5
	4.0	1.14	342	274	228	195	171	137	114	85.5	76.0	68.4	54.7
	5.0	1.28	384	307	256	219	192	154	128	96.0	85.3	76.8	61.4
<b>Blue 03</b>	1.5	0.83	249	199	166	142	125	99.6	83.0	62.3	55.3	49.8	39.8
	2.0	0.96	288	230	192	165	144	115	96.0	72.0	64.0	57.6	46.1
	2.5	1.08	324	259	216	185	162	130	108	81.0	72.0	64.8	51.8
	3.0	1.18	354	283	236	202	177	142	118	88.5	78.7	70.8	56.6
	4.0	1.36	408	326	272	233	204	163	136	102	90.7	81.6	65.3
	5.0	1.52	456	365	304	261	228	182	152	114	101	91.2	73.0
<b>Red 04</b>	1.5	1.12	336	269	224	192	168	134	112	84.0	74.7	67.2	53.8
	2.0	1.29	387	310	258	221	194	155	129	96.8	86.0	77.4	61.9
	2.5	1.44	432	346	288	247	216	173	144	108	96.0	86.4	69.1
	3.0	1.58	474	379	316	271	237	190	158	119	105	119	105
	4.0	1.82	546	437	364	312	273	218	182	137	121	109	87.4
	5.0	2.04	612	490	408	350	306	245	204	153	136	122	97.9



# **SPRAYING SYSTEMS**

**Directo valve**

**Electric – Shut Off**

**Ball Valve**

**Parts Breakdown**

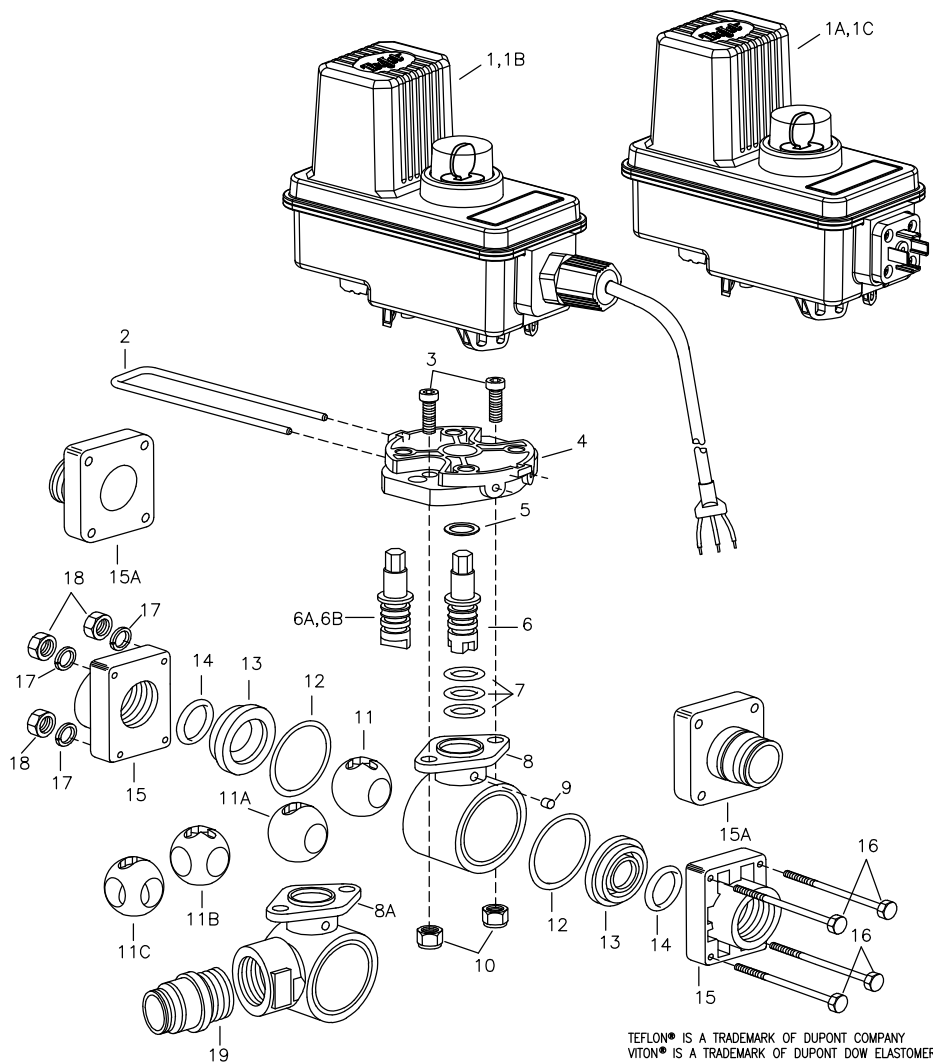

TEFLON® IS A TRADEMARK OF DUPONT COMPANY  
 VITON® IS A TRADEMARK OF DUPONT DOW ELASTOMERS

ITEM	PART NO.	DESCRIPTION
1	50515-22CP03 ■	BEC MOTOR, 22-RPM (0.7-SEC), 0.3-METER CABLE, POSITIVELY SWITCHED
	50515-22CP05 ■	BEC MOTOR, 22-RPM (0.7-SEC), 0.5-METER CABLE, POSITIVELY SWITCHED
	50515-22CP15 ■	BEC MOTOR, 22-RPM (0.7-SEC), 1.5-METER CABLE, POSITIVELY SWITCHED
	50515-22CP60 ■	BEC MOTOR, 22-RPM (0.7-SEC), 6.0-METER CABLE, POSITIVELY SWITCHED
1A	50515-22DP ■	BEC MOTOR, 22-RPM (0.7-SEC), DIN CONNECTION, POSITIVELY SWITCHED
	50533-22C03	BE MOTOR, 22-RPM (0.7-SEC), 0.3-METER CABLE
1B	50533-22C05	BE MOTOR, 22-RPM (0.7-SEC), 0.5-METER CABLE
	50533-22C15	BE MOTOR, 22-RPM (0.7-SEC), 1.5-METER CABLE
	50533-22C60	BE MOTOR, 22-RPM (0.7-SEC), 6.0-METER CABLE
1C	50533-22D	BE MOTOR, 22-RPM (0.7-SEC), DIN CONNECTION
2	CP50517-SSPV	RETAINING CLIP, 304 STAINLESS STEEL
3	CP26197-7/8-SS	SOCKET HEAD CAP SCREW, STAINLESS STEEL (2 REQ'D)
4	CP50514-PP	MOTOR ADAPTER, POLYPROPYLENE (BLACK)
5	CP20125-TEF	THRUST WASHER, TEFLON
6	CP56613-SS	STEM, 303 STAINLESS STEEL (FOR POLYPROPYLENE BALL)
6A	CP56615-SS	STEM, 303 STAINLESS STEEL (FOR 2-WAY STAINLESS STEEL BALL)
6B	CP56725-SS	STEM, 303 STAINLESS STEEL (FOR 3-WAY STAINLESS STEEL BALL)
7	CP7717-M12X2.5-VI	O-RING, VITON (3 REQ'D)
8	CP20101-NYB	BODY, NYLON (BLACK) (2-WAY)
8A	CP20102-3/4-NYB	BODY, NYLON (BLACK) (3-WAY, 3/4" NPT THREAD)
	CPB20102-3/4-NYB	BODY, NYLON (BLACK) (3-WAY, 3/4" BSPT THREAD)
	CP20102-1-NYB	BODY, NYLON (BLACK) (3-WAY, 1" NPT THREAD & QUICK CONNECT)
	CPB20102-1-NYB	BODY, NYLON (BLACK) (3-WAY, 1" BSPT THREAD)
9	CP20126-FELT	DUST PLUG, FELT
10	CP38435-1/4-SSNY	ELASTIC LOCKNUT, STAINLESS STEEL (2 REQ'D)
11	CP20106-1-PP	BALL, POLYPROPYLENE (WHITE) (2-WAY)
11A	CP19926-SS	BALL, STAINLESS STEEL (2-WAY)
11B	CP20109-1-PP	BALL, POLYPROPYLENE (WHITE) (3-WAY)
11C	CP45510-1-SS	BALL, STAINLESS STEEL (3-WAY)
12	CP20564-VI	GASKET, VITON (2 REQ'D)
13	CP20103-TEF	SEAL, TEFLON (2 REQ'D)
14	CP7717-2-213-VI	O-RING, VITON (2 REQ'D)
	CP20104-3/4-NYB	END CAP, NYLON (BLACK) (3/4" NPT THREAD) (2 REQ'D)
15	CPB20104-3/4-NYB	END CAP, NYLON (BLACK) (3/4" BSPT THREAD) (2 REQ'D)
	CP20104-1-NYB	END CAP, NYLON (BLACK) (1" NPT THREAD) (2 REQ'D)
	CPB20104-1-NYB	END CAP, NYLON (BLACK) (1" BSPT THREAD) (2 REQ'D)
15A	CP45514-NYB	END CAP, NYLON (BLACK) (QUICK CONNECT) (2 REQ'D)
16	CP20129-SS	BOLT, 1/4"-20 X 3" HEX, STAINLESS STEEL (4 REQ'D)
17	CP20128-SS	LOCK WASHER, 1/4", STAINLESS STEEL (4 REQ'D)
18	CP8535-SS	NUT, 1/4"-20 HEX, STAINLESS STEEL (4 REQ'D)
19	CP45526-NYB	THREADED QUICK CONNECT ADAPTER, NYLON (BLACK) (3-WAY ONLY)
20	56601-_-_-_-	VALVE BODY SUB-ASS'Y, SPECIFY OUTLET SIZE & BALL MATERIAL, INCLUDES ITEMS 3-19
AB344AE-KIT, SPARE PARTS KIT (INCLUDES ALL ITEMS MARKED WITH *)		

NOTE: (B) IN PART NUMBER INDICATES B.S.P.T INLET AND OUTLET CONNECTIONS  
 ■ NOTE: FOR NEGATIVELY SWITCHED MOTORS SPECIFY "N" RATHER THAN "P" IN MOTOR PART NUMBER  
 EXAMPLE: 50515-22CN05

**DESCRIPTION:**  
 344BE AND 344BEC  
 DIRECTVALVE®  
 ELECTRIC SHUT-OFF  
 BALL VALVE



**Spraying Systems Co.®**  
 Spray Nozzles and Accessories  
 P.O. Box 7900 - Wheaton, IL 60189-7900

Rev. No. 3	PARTS LIST PL344BEC
Ref.	SHEET OF

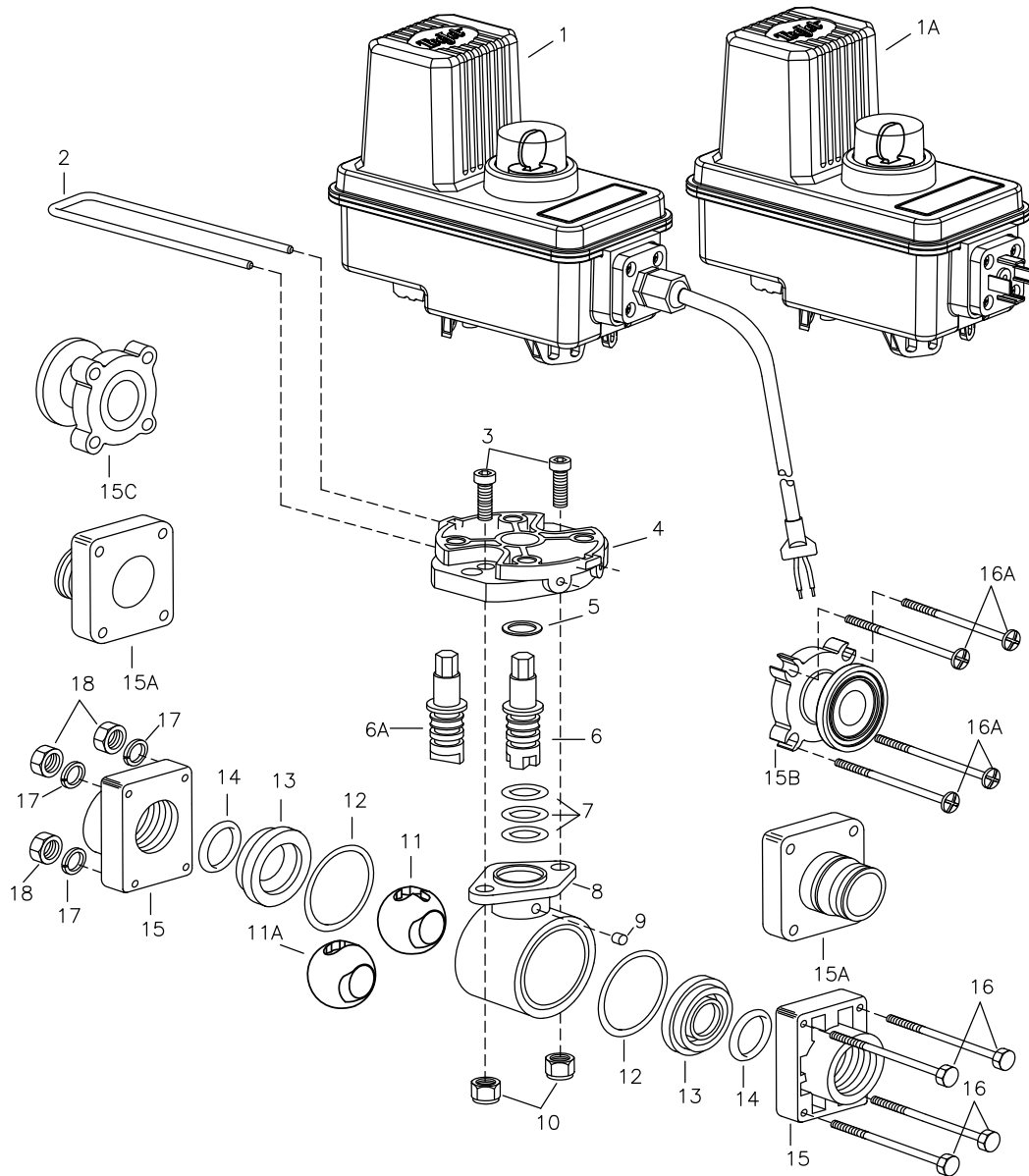

ITEM	PART NO.	DESCRIPTION	
1	50516-01C--	REGULATING MOTOR, 1-RPM, (18-SEC), 2-WIRE JACKETED CABLE	
	50516-03C--	REGULATING MOTOR, 3-RPM, (6-SEC), 2-WIRE JACKETED CABLE	
	50516-06C--	REGULATING MOTOR, 6-RPM, (3-SEC), 2-WIRE JACKETED CABLE	
1A	50516-01D	REGULATING MOTOR, 1-RPM, (18-SEC), DIN CONNECTION	
	50516-03D	REGULATING MOTOR, 3-RPM, (6-SEC), DIN CONNECTION	
	50516-06D	REGULATING MOTOR, 6-RPM, (3-SEC), DIN CONNECTION	
2	CP50517-SSPV	RETAINING CLIP, 304 STAINLESS STEEL	
3	CP26197-7/8-SS	SOCKET HEAD CAP SCREW, STAINLESS STEEL (2 REQ'D)	
4	CP50514-PP	MOTOR ADAPTER, POLYPROPYLENE (BLACK)	
*	5	CP20125-TEF	THRUST WASHER, TEFLON
6	CP56613-SS	STEM, 303 STAINLESS STEEL (FOR POLYPROPYLENE BALL)	
6A	CP56615-SS	STEM, 303 STAINLESS STEEL (FOR STAINLESS STEEL BALL)	
*	7	CP7717-M12X2.5-VI	O-RING, VITON (3 REQ'D)
8	CP20101-NYB	BODY, NYLON (BLACK) (2-WAY)	
*	9	CP20126-FELT	DUST PLUG, FELT
10	CP38435-1/4-SSNY	ELASTIC LOCKNUT, STAINLESS STEEL (2 REQ'D)	
11	CP22259-2-PP	RL BALL, POLYPROPYLENE (WHITE) (BRL VALVE)	
11A	CP38441-1-SS	RL BALL, 303 STAINLESS STEEL (BRL VALVE)	
*	12	CP20564-VI	GASKET, VITON (2 REQ'D)
*	13	CP20103-TEF	SEAL, TEFLON (2 REQ'D)
*	14	CP7717-2/213-VI	O-RING, VITON (2 REQ'D)
15	CP20104-3/4-NYB	END CAP, NYLON (BLACK) (3/4" NPT THREAD) (2 REQ'D)	
	CPB20104-3/4-NYB	END CAP, NYLON (BLACK) (3/4" BSPT THREAD) (2 REQ'D)	
	CP20104-1-NYB	END CAP, NYLON (BLACK) (1" NPT THREAD) (2 REQ'D)	
	CPB20104-1-NYB	END CAP, NYLON (BLACK) (1" BSPT THREAD) (2 REQ'D)	
15A	CP45514-NYB	END CAP, NYLON (BLACK) (QUICK CONNECT) (2 REQ'D)	
15B	CP45253-NYB	END CAP, NYLON (BLACK) (FLANGE) (1 REQ'D)	
15C	CP48265-NYB	END CAP, NYLON (BLACK) (FLANGE) (1 REQ'D)	
16	CP20129-SS	BOLT, 1/4"-20 X 3" HEX, STAINLESS STEEL (4 REQ'D) (THD & QC)	
16A	CP45252-2-3/4-SSPV	SCREW, PAN HEAD, STAINLESS STEEL (4 REQ'D) (FLANGE VERSION)	
17	CP20128-SS	LOCK WASHER, 1/4", STAINLESS STEEL (4 REQ'D) (THD & QC)	
18	CP8535-SS	NUT, 1/4"-20 HEX, STAINLESS STEEL (4 REQ'D) (THD & QC)	

AB344AE-KIT, SPARE PARTS KIT (INCLUDES ALL ITEMS MARKED WITH \*)

NOTE: (B) IN PART NUMBER INDICATES B.S.P.T INLET AND OUTLET CONNECTIONS  
 \* NOTE: FOR JACKETED CABLE MOTORS SPECIFY CABLE LENGTH IN PART NUMBER--  
 03 (0.3-METER), 05 (0.5-METER), 15 (1.5-METER) OR 60 (6.0-METER).

<b>DESCRIPTION:</b> 344BRL DIRECTVALVE® LINEAR REGULATING ELECTRIC BALL VALVE	 <b>Spraying Systems Co.®</b> Spray Nozzles and Accessories P.O. Box 7900 - Wheaton, IL 60187-7901
PARTS LIST <b>PL344BRL</b> SHEET OF	

TeeJet 801 FM Assemblies		Mid-Tech 801 FM Assemblies		Hose Connection Option	
P/N	Description	P/N	Description	P/N	Description
90-50231	801 w/ 3/4" HB	90-02175	801 w/ 3/4" HB	57-10112*	3/4" Hose Barb
90-50230	801 w/ 1" HB	90-02176	801 w/ 1" HB	57-10113*	1" Hose Barb
90-50232	801 w/1_1/4" HB	90-02177	801 w/1_1/4" HB	57-10114*	1_1/4" Hose Barb
90-50233	801 w/1_1/4" NPT (F)	90-02178	801 w/1_1/4" NPT (F)	57-10115*	1_1/4" NPT (F)
Above assemblies include flow meter interface cable 45-05315				(*) 2 Required per 57-10100 flow meter	
Note: Also requires 2 flange clamp (50 series) assemblies 90-50229					

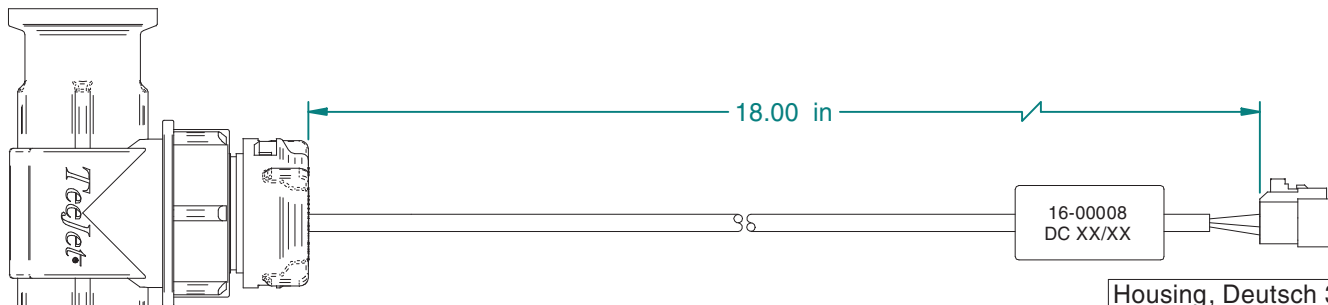
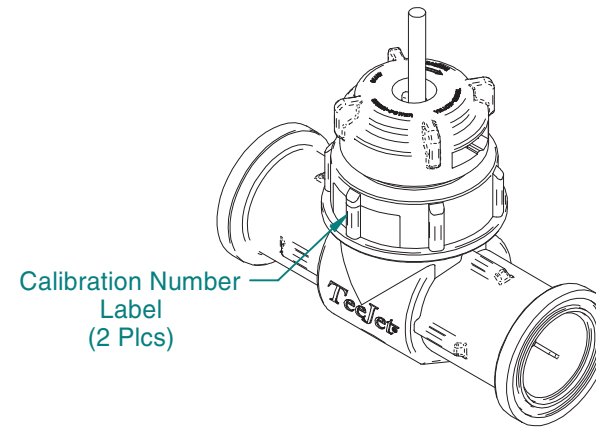
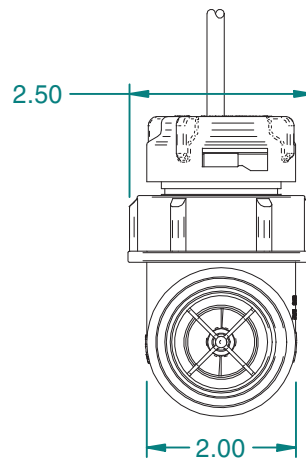
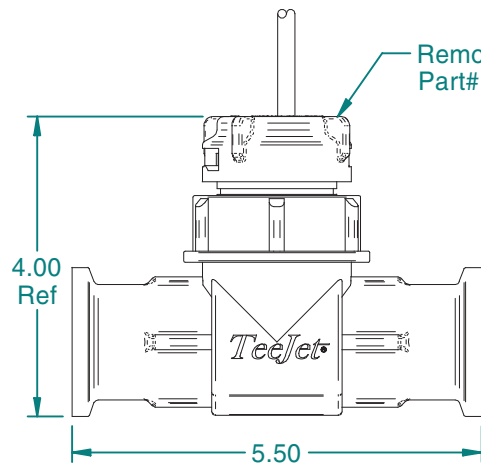

Housing, Deutsch 3 Pos/Skts		
Pin Out	Color	Function
A	Red	(+ 12V)
B	White	Signal
C	Black	Ground

- Material:**
- 303 Stainless Steel
  - 410 Stainless Steel
  - Nylon
  - Polypropylene
  - Ruby
  - Sapphire

- Features:**
- Efficient helical turbine design
  - Easy access to turbine assembly for cleaning and maintenance
  - Flange mount design for flexible installation options
  - 2.5-60 GPM (10-225 LPM)

**Notes:**

- Approximate calibration #82 pulses/lit - 310 pulses/gal.
- Vertical mounting position recommended
- 12 inches (30cm) of uninterrupted flow required before the flow meter and 6 inches (15cm) of uninterrupted flow required after flow meter.
- 45-05315 Flow meter interface cable required for Mid-Tech controls.

MATERIAL: See Notes		FINISH: See Notes		TITLE: Flowmeter, 801	
PROJECTION:		SCALE: 2:1		UNITS: INCH: X METRIC: <input type="checkbox"/>	
UNLESS OTHERWISE SPECIFIED TOLERANCES:					
0-1" +/- .1"		10-60" +/- 1"		.XX	
1-5" +/- .25"		60-120" +/- 2"		.XXX	
5-10" +/- .5"		120" +/- 3"		.4	
REV. R1	DATE 6/15/05	UPDATED	DRAWN BY: Bryan Reiser	SHEET No: 1 of 2	
REV. R0	DATE 8/14/02	010117	CHECKED BY: Amy Newbern	DWG No: C-57-10100	
REV.	DATE	NOC. No	APPROVED BY: Scott Leuber		

Midwest Technologies IL, LLC. Claims proprietary right in the material disclosed hereon. This document is not to be used in any way detrimental to the interest of Midwest Technologies IL, LLC.

Item	Description	Part Number	QTY	U.M.
1	Sensor, PCB Assembly	16-00008	1	EA
2	O-Ring, 35mmx3mm	57-00065	1	EA
3	Turbine Assembly 801 FM	57-10108	1	EA
4	Guide Vane Bearing	57-10109	2	EA
5	Washer, Seat, 801	57-10111	1	EA
6	Screw, #6-5/8" LG Flat Head	60-04031	2	EA
7	Body, 801 Flowmeter	64-50044	1	EA
8	Endcap, 801 Flowmeter	64-50045	1	EA
9	Retaining, Nut 801 FM	64-50046	1	EA
10	Insert, Body 801 FM	64-50047	1	EA

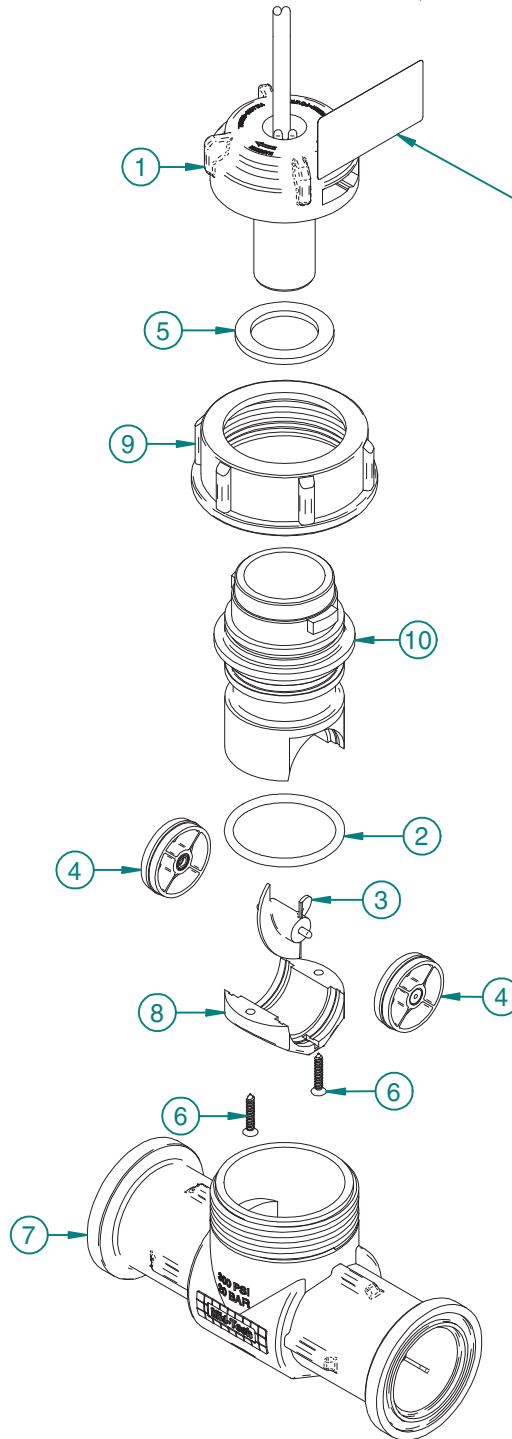

Approximate Calibration #'s  
 TeeJet - 82  
 Mid-Tech - 310  
 2-60 gpm DC:xx/xx

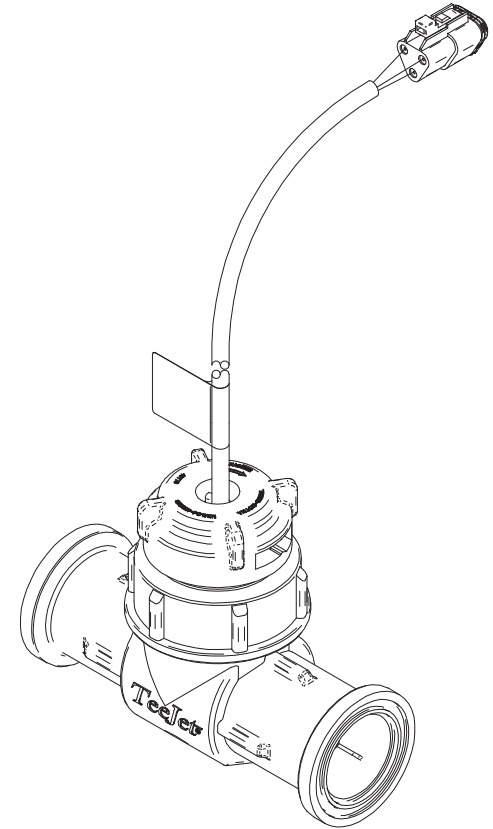
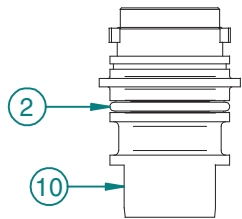

		MATERIAL:	N/A	
		FINISH:	N/A	
		TITLE: Flowmeter, 801		DRAWN BY: <i>Bryan Reiser</i> CHECKED BY: <i>Amy Newbern</i>
		PROJECTION:  SCALE: 2:1 UNITS: INCH: X METRIC:		
		UNLESS OTHERWISE SPECIFIED TOLERANCE:		APPROVED BY: <i>Scott Leuber</i> SHEET No: <b>2of2</b> DWG No: <b>C-57-10100</b>
R1	6/15/05	UpDated	0-1" +/- .1"    10-60" +/- 1"    .XX 1-5" +/- .25"    60-120" +/- 2"    .XXX 5-10" +/- .5"    120" +/- 3"    Z	
REV.	DATE	NOC. No		

Midwest Technologies IL, LLC. Claims proprietary right in the material disclosed hereon. This document is not to be used in any way detrimental to the interest of Midwest Technologies IL, LLC.

# **HYPRO**

## **Series 9300 Hydraulically- Driven Centrifugal Pumps**

### **Installation, Operation, Repair and Parts Manual**





**Series 9300 Hydraulically-Driven Centrifugal Pumps**

Form L-1526  
1/10

**Installation, Operation, Repair and Parts Manual**

**Description**

Hypro centrifugal pumps are designed for agricultural and industrial spraying and transfer of a variety of fluids: water, insecticides, herbicides, wettable powders, emulsives, liquid fertilizers, etc. Polypropylene centrifugal pumps may also be used to pump acid fertilizer, calcium chloride and other highly corrosive liquids such as sulfuric and phosphoric acids.

Hypro Series 9300 hydraulic motor-driven centrifugal pumps provide smooth performance. They can be conveniently mounted on the tractor or sprayer, becoming part of the vehicle's hydraulic system and freeing the PTO for other uses. The Hypro "close-coupled" design reduces the mounting space required, eliminating long shafts and couplers between the pump and motor.



**SERIES 9302C & 9302S**  
Cast Iron & Stainless Steel Centrifugal Pumps

Max. Flow Rate: .....100 gpm  
Max. Pressure: .....120 psi  
Ports: .....1-1/4" NPT Inlet  
.....1" NPT Outlet  
Hydraulic Ports: .....1/2" NPT Inlet  
.....1/2" NPT Tank



**SERIES 9303C & 9303S**  
Cast Iron & Stainless Steel Centrifugal Pumps

Max. Flow Rate: .....147 gpm  
Max. Pressure: .....145 psi  
Ports: .....1-1/2" NPT Inlet  
.....1-1/4" NPT Outlet  
Hydraulic Ports: .....1/2" NPT Inlet  
.....1/2" NPT Tank



**SERIES 9303P**  
Polypropylene Centrifugal Pumps

Max. Flow Rate: .....113 gpm  
Max. Pressure: .....125 psi  
Ports: .....1-1/2" NPT Inlet  
.....1-1/4" NPT Outlet  
Hydraulic Ports: .....1/2" NPT Inlet  
.....1/2" NPT Tank



**SERIES 9303C-SP**  
Cast Iron Centrifugal Pumps

Max. Flow Rate: .....122 gpm  
Max. Pressure: .....140 psi  
Ports: .....1-1/2" NPT Inlet  
.....1-1/4" NPT Outlet  
Hydraulic Ports: .....1/2" NPT Inlet  
.....1/2" NPT Tank



**SERIES 9304C**  
Cast Iron Centrifugal Pumps

Max. Flow Rate: .....190 gpm  
Max. Pressure: .....130 psi  
Ports: .....2" NPT Inlet  
.....1-1/2" NPT Outlet  
Hydraulic Ports: .....1/2" NPT Inlet  
.....1/2" NPT Tank



**SERIES 9305C-HM3C**  
Cast Iron Centrifugal Pumps

Max. Flow Rate: .....190 gpm  
Max. Pressure: .....180 psi  
Ports: .....2" NPT Inlet  
.....1-1/2" NPT Outlet  
Hydraulic Ports: .....1/2" NPT Inlet  
.....1/2" NPT Tank



**SERIES 9305C-HM3C-SP, -BSP**  
Cast Iron Centrifugal Pumps

Max. Flow Rate: .....178 gpm  
Max. Pressure: .....154 psi  
Ports: .....2" NPT or BSP Inlet  
.....2" NPT or BSP Outlet  
Hydraulic Ports: .....1/2" NPT Inlet  
.....1/2" NPT Tank



**SERIES 9306C & 9306S**  
Cast Iron & Stainless Steel Centrifugal Pumps

Max. Flow Rate: .....214 gpm  
Max. Pressure: .....150 psi  
Ports: .....2" NPT Inlet  
.....1-1/2" NPT Outlet  
Hydraulic Ports: .....1/2" NPT Inlet  
.....1/2" NPT Tank

## General Safety Information

### NOTE

Notes are used to notify of installation, operation, or maintenance information that is important but not safety related.

### CAUTION

Caution is used to indicate the presence of a hazard, which will or may cause minor injury or property damage if the notice is ignored.

### WARNING

Warning denotes that a potential hazard exists and indicates procedures that must be followed exactly to either eliminate or reduce the hazard, and to avoid serious personal injury, or prevent future safety problems with the product.

### DANGER

Danger is used to indicate the presence of a hazard that will result in severe personal injury, death, or property damage if the notice is ignored.

### DANGER

Do not pump flammable or explosive fluids such as gasoline, fuel oil, kerosene, etc. Do not use in explosive atmospheres. The pump should be used only with liquids compatible with the pump component materials. Failure to follow this notice may result in severe personal injury and/or property damage and will void the product warranty.

### CAUTION

1. Do not pump at pressures higher than the maximum recommended pressure.
2. Maximum liquid temperature is 140° F for Series 9300 centrifugal pumps.
3. Disconnect power before servicing.
4. Release all pressure within the system before servicing any component.
5. Drain all liquids from the system before servicing any component. Flush with water.
6. Secure the outlet lines before starting the pump. An unsecured line may whip, causing personal injury and/or property damage.
7. Check hose for weak or worn condition before each use. Make certain that all connections are tightly secured.
8. Periodically inspect the pump and the system components. Perform routine maintenance as required (See Repair Instructions).
9. Use only pipe, hose and fittings rated for the maximum psi rating of the pump.
10. Do not use these pumps for pumping water or other liquids for human or animal consumption.

## Hazardous Substance Alert

### CAUTION

1. Always drain and flush pump before servicing or disassembling for any reason.
2. Always drain and flush pumps prior to returning unit for repair.
3. Never store pumps containing hazardous chemicals.
4. Before returning pump for service/repair, drain out all liquids and flush unit with neutralizing liquid. Then, drain the pump. Attach tag or include written notice certifying that this has been done. It is illegal to ship or transport any hazardous chemicals without United States Environmental Protection Agency Licensing.

### DANGER

Never use your hand to check the condition of hydraulic lines or hoses. If hydraulic fluid penetrates the skin, get medical help immediately. Failure to get proper medical help may result in loss of limb or life. The safest way to check hydraulic lines or hoses is by holding a piece of cardboard next to the hydraulic line or hose.

### WARNING

The sound pressure level of the pump is 80dBA. Observe all safety precautions when operating the pump within close proximity for extended periods of time by wearing hearing protectors. Extended exposure to elevated sound levels will result in permanent loss of hearing acuteness, tinnitus, tiredness, stress, and other effects such as loss of balance and awareness.

## General Information—Hydraulic Systems

### Hydraulic Pumps

Hydraulic pumps come in two basic types:

- **Constant displacement** - which will continue to put out its rated flow regardless of pressure, until the relief valve bypasses the flow.
- **Variable displacement** - which will produce only the flow needed by the implement until the total pump output is reached. If less than the full pump output is required, an automatic stroke control mechanism decreases the pump output to maintain a constant pressure and flow. The output varies according to demand.

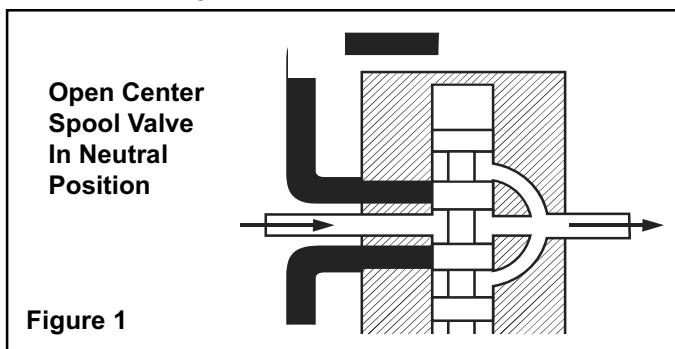

Figure 1

### Spool Valves

There are two basic types of spool valves used in conjunction with these pumps — Open and Closed Center. In the Open Center Valve (See Figure 1), the flow goes straight through the valve when in the neutral position. This type is used for constant displacement pumps where the flow should never be shut off.

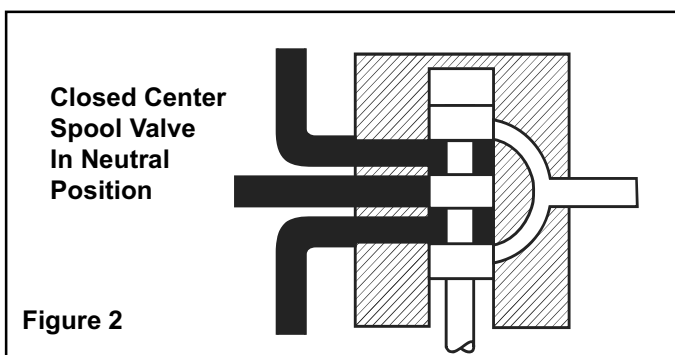

Figure 2

The Closed Center Valve (See Figure 2) is used with variable displacement pumps. The flow is completely shut off in the neutral position, causing the pump stroke to adjust to zero flow. The flow stops, but the pump maintains a static pressure up to the valve.

### Hydraulic Motors

Figure 3 shows an internal gear motor (Gerotor) where pressure causes the cavities between the gears to expand on one side, developing torque. The Gerotor type of hydraulic motor is used on Hypro pumps for its superior performance characteristics, including cooler running and higher rpm capabilities.

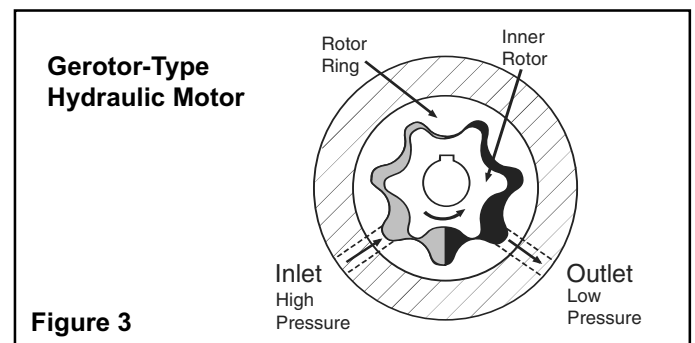

Figure 3

### Three Systems

Fitting these components together and installing a motor, we have one of the three types of systems: Open Center, Closed Center (pressure compensated) and Closed Center Load Sensing (flow and pressure compensated).

#### Open Center Systems

In an Open Center System, the hydraulic pump puts out a constant flow. If the pump puts out more oil than the motor can use, a portion of the oil must be bypassed around the motor. When the oil is bypassed around a loop and does not work, the energy put into it by the pump turns into heat. Therefore, the amount of oil bypassed should be kept to a minimum. Use the largest motor possible.

#### Closed Center (Pressure-Compensated) Systems

The Closed Center Pressure-Compensated system has a variable displacement pump which will deliver flow at the necessary rate to maintain a specified pressure. It is desirable to equip implements with a motor of a low flow range that will cause the pump to operate between 1800 and 2100 psi [124 and 145 BAR]. A motor that requires a large volume to obtain the correct implement speed usually causes the hydraulic pump in a closed center system to operate at a lower pressure than desirable. This low pressure results in unnecessary flow and the generation of heat that lowers the lubricating quality of the oil and may damage transmission parts. Use the smallest motor possible.

#### Closed Center Load Sensing Systems (Flow and Pressure-Compensating)

The Closed Center Flow-Compensated System is a variation of the pressure-compensated system, designed primarily for more efficient operation and the generation of less heat. It works on the principle of maintaining a constant pressure drop from the pump to the work port of the selector valve. Any variation in demand at the motor will cause a change in flow. The system senses this change in flow due to the change in pressure drop across the valve and causes the pump to compensate by varying the pump flow. No restrictor is used in the pressure line and no oil is bypassed.

## Plumbing Installation

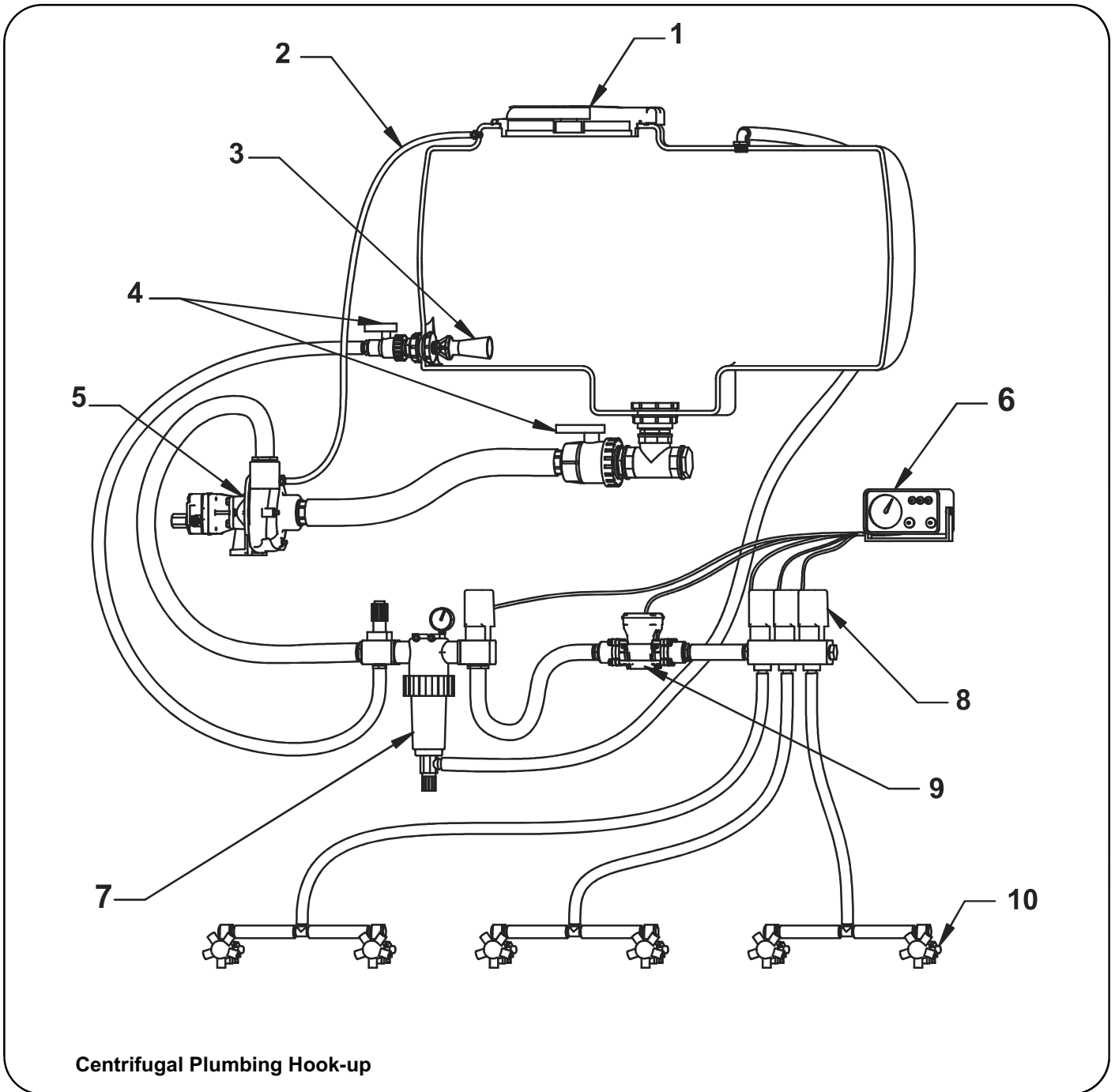

**Centrifugal Plumbing Hook-up**

REF. NO.	DESCRIPTION
1	Tank Lid
2	Vent Line #3430-0456
3	Jet Agitator
4	Shut-off Ball Valves
5	Centrifugal Pump
6	Spray Control Console
7	Centrifugal Pump Control
8	Manifold Boom Valve
9	Electromagnetic Flowmeter
10	Compact Jet Turret Nozzle Body

## Installation Instructions

### All Models — Open Center Systems

Models include Tank Port Adapter with built-in Check Valve Assembly and Pressure Port Adapter.

### HM2C and HM4C Models Only — Closed Center and Small Open Center Systems.

Models include Tank Port Adapter with built-in Check Valve Assembly and Pressure Port Adapter with three different size metering orifices for HM4C models. The orifices are not required for use with closed center systems with flow control, such as John Deere closed center systems. Also, do not use for small open center systems with a maximum flow of 8 gpm [30.28 lpm] for HM2C model; 10 gpm [37.85 lpm] for HM4C model. If necessary, the pressure port adapter may be used without a metering orifice installed in any closed center system. For best results, the pressure differential across the motor should be less than 2500 psi (170 bar).

### Preliminary to Mounting

Consult the owners manual to determine the type and capacity of the hydraulic system. Make sure the hydraulic system is recommended to operate with a continuous load. Refer to the Pump Selection Guide to confirm you have the proper pump for your hydraulic system.

Check to see that the pump impeller can be turned by hand. (Turn the shaft clockwise using a deep socket wrench on the impeller nut.) If it cannot be turned, open the pump casing to look for obstructions. Clean out any corrosion build up where the casing fits over the eye of the impeller.

### Pump Inlet Line

To achieve full capacity from the pump, the inlet line should be at least the same size as the inlet port on the pump. Reducing this line size will restrict the capabilities of the pump. The line must also be free of air leaks. Check all fittings and connections in the suction line for tightness. The introduction of air may affect the priming and pumping capabilities of the pump. Use good quality suction hose that will not be collapsed by suction.

For non self-priming models, the centrifugal pump should be mounted below the liquid level and as near to the liquid source as possible to allow for the shortest suction line practical. To achieve optimal performance, the suction line should slope down into the pump. Avoid rises and humps that could trap air in the line to the pump. The suction line and pump should be filled with liquid prior to starting the pump, and all discharge lines should be open.

### Pump Outlet Line

The recommended orientation for the outlet port is pointing straight up. This allows liquid to stay in the pump while it is priming. The outlet line should be the same size as the pressure port on the pump to give the optimal flow. The line should have as few restrictions and elbows as possible to optimize the pump performance and reduce pressure drop from the pump to the spray tips.

### Priming the Pump

#### NOTE

#### The pump must not be run dry.

Before starting the pump, the inlet line and pump must be filled with liquid and all discharge lines must be open. On self-priming models, only the pump chamber needs to be filled with liquid. The pump must not be run unless it is completely filled with liquid because there is a danger of damaging the mechanical seal, which depends on the liquid for its lubrication.

Non-self-priming models should be mounted below the level of the liquid. The suction line should slope down to the pump and be free of dips and bends. If this cannot be done, a foot valve should be installed in the end of the inlet line so that the line can be completely filled with liquid before starting the pump.

**For best priming results, the top vent plug should be removed from the pump casing. A vent line (1/4" [6.35 mm] tubing is sufficient) should be installed running back to the top of the tank.** This line prevents air lock and allows the pump to prime itself by bleeding off trapped air. The small stream of liquid that returns to the tank during operation is negligible. The discharge from this line should be positioned in the tank above the high liquid level. Self-priming models can be primed by removing the top vent plug and filling the priming chamber. The priming chamber will fill to the level of the inlet port. After use, the priming chamber should be flushed and drained to avoid chemical corrosion and damage from freezing. Drain by removing the lower drain plug.

### Controlling the Pump Flow

The best way to control the flow is by incorporating two control valves in a pipe tee immediately after the strainer in the discharge line. This permits controlling agitation flow independently of nozzle flow.

In any centrifugal pump, it is the large volume of liquid which puts load on the drive. Use only the flow needed to develop the pressure required at the boom and to maintain adequate agitation. Hydraulic motor-driven centrifugal pumps are easily adjusted to the exact flow required, as explained in the Operating Instructions of this manual.

### Centrifugal Pump Control

Hypro now offers many different components for spraying systems. The Hypro centrifugal pump control incorporates the electric flow control valve, a self-cleaning line strainer, a visual pressure gauge and a manual agitation control valve.

### Flow Control Valve

A high-flow electric proportional valve allows for maximum flow control to the boom valves. It provides smooth, rapid control that can be controlled from either an electronic rate controller or switch box.

### Strainers

The recommended placement of the strainer for a centrifugal pump is in the pump outlet line. This will eliminate any possible restriction that the strainer could

## Plumbing Installation

create if it were installed in the inlet line. Ensure that the proper strainer size and screen mesh are used to limit the pressure drop and achieve the best filtration. Line strainers can also be installed in the tank fill line to filter liquid as it is loaded into the tank as well as in the boom lines to further filter the solution prior to the spray tips. Tank baskets can also be used to filter material added through the tank lid.

### Agitation

The centrifugal pump control contains a manual agitation control valve that can be adjusted to provide the right amount of flow to the jet agitators in the tank to ensure proper mixing within the tank.

### Flowmeter

To eliminate the mechanical problems of a turbine flowmeter, we recommend that an electromagnetic flowmeter be used. These flowmeters have no moving parts to wear out and will provide a more consistent and accurate flow reading. They can be input into just about any electronic rate controller or switch box.

### Boom Section Valves

For rapid response and reliability, we recommend electric plunger valves be used for boom control. The valves should be sized accordingly to minimize the pressure drop and maximize the flow rate. The boom tubing or hose should be sized accordingly to ensure that a pressure drop in the lines does not occur, causing inconsistent pressures at the nozzles.

### Nozzle Bodies

Nozzle bodies with shut-off check valves are recommended to eliminate dripping from the spray tips when the boom valves are shut down.

### Hooking Up the Hydraulic Motor to the Tractor Hydraulic System

Hypro Series 9300HMC hydraulic motor-driven pumps can be mounted on either the tractor or sprayer. When hooking up, make sure that no dirt or liquid gets into the hydraulic motor. **Keep all hydraulic connections clean.** Be sure to connect the hydraulic motor into the system correctly by

putting the pressure line to the Pressure Port Adapter and return line to the Tank Port Adapter. The adapters on the hydraulic motor are sized to accommodate 1/2" NPT fittings on the pressure port and 3/4" NPT on the tank port. For maximum performance, the hydraulic lines should also be at least 1/2" [12.7 mm] in size for the pressure line and 3/4" [19.05 mm] for the tank line.

The tank (**OUT**) port adapter with a built-in check valve assembly will guard against reverse operation — allowing you to reverse oil flow to operate other equipment. **This adapter must not be removed.** On HM2C and HM4C model pumps, the pressure (**IN**) port adapter is a two-piece assembly consisting of an open (unrestricted) adapter with three orifices packed loose with the pump. (See the Operations Section.)

When using the HM2C or HM4C unit on any flow-compensated (load sensing) closed center system, or any small open center system with a maximum flow of 8 gpm [30.28 lpm] for HM2C or 10 gpm [37.85 lpm] for HM4C, the metering orifice should be removed from the pressure port adapter. When using these units on flow-compensated systems, connect to the motor priority circuit if your tractor has one.

Standard spool valves, which are found on all tractor hydraulic systems, may cause potentially damaging high peak pressures in the hydraulic system when closed because of abrupt shut-off of oil flow in both the supply and return lines. When shutting off the pump, move the selector to the **FLOAT** position to allow the centrifugal pump to come to a stop gradually.

**For further information  
regarding Hypro products,  
contact your local dealer or  
Hypro directly at  
[www.hypropumps.com](http://www.hypropumps.com) or by  
calling 1-800-424-9776.**

## Operation

### Open Center Systems— All Models Adjusting Centrifugal Pump Output

#### [NOTE]

HM1C, HM3C & HM5C motors have bypass screw fully closed from the factory. HM2C & HM4C motors have bypass screw set at 1-1/2 turns from fully closed from the factory.

1. Open the bypass adjustment screw 2-1/2 turns from fully closed. Turn the bypass screw in to achieve the flow for the desired gpm and psi.
2. Start the tractor. Leave the directional valve in the neutral position and allow hydraulic oil to circulate for approximately 10 to 15 minutes or until adequately warmed.
3. Prime the centrifugal pump with all valves open (See the Installation Instructions and System Configuration Diagram).
4. Close the agitation line valve and keep the control valve and the boom shut-off valve open. Note the spray pressure.
5. Open the agitation line valve until you have desired circulation in the tank. Recheck the spray pressure. If it is too low, close down the agitation line valve until the desired spray pressure is reached. If the spray pressure is too high, throttle the centrifugal pump by closing down the control valve.



### **Closed Center (Pressure-Compensated) — HM2C and HM4C Models Only**

On a pressure-compensated system, the amount of oil that is allowed to flow through the hydraulic motor is regulated by a metering orifice in the pressure port adapter. Three different sizes of orifices are supplied with the HM2C and HM4C model pumps to allow flexibility in the flow required for individual sprayer needs.

The smaller the orifice, the less hydraulic oil goes through the motor, so the pump will run slower and the flow of liquid pumped and the spray pressure will also be less. As the hydraulic oil flow is increased (by installing a larger orifice), the amount of liquid being pumped and the spray pressure is also increased.

#### **Installing and Removing Metering Orifice**

1. Shut off the hydraulic system.
2. Disconnect the line to the pressure port of the hydraulic motor.
3. Remove the adapter from the motor using a 1-1/16" wrench. Make sure the o-ring is on the metering orifice before installing into port adapter.
4. The orifice is removed or installed in the port adapter by tapping either in or out of the adapter.
  - A. To remove — tap the orifice out from the small end of the adapter.
  - B. To install — tap the orifice in from the large end of the adapter. The orifice is seated when a snap sound is heard.

#### **Adjusting Centrifugal Pump Output**

1. Open the bypass adjusting screw in the hydraulic motor three (3) turns.
2. Start the tractor and allow the hydraulic oil to circulate for approximately 10 to 15 minutes or until adequately warmed.
3. Close and lock down the bypass adjusting screw in the hydraulic motor.
4. Prime the centrifugal pump with all valves open (See Installation Instructions and System Configuration Diagram).
5. Close the agitation line valve and the control valve; open the boom shut-off valve.
6. With the pump running, open the control valve until the pressure gauge indicates the desired spraying pressure.
7. Open the agitation line valve until sufficient agitation is observed. Then, if spray pressure drops, readjust the control valve to restore to the desired pressure.
8. If a sufficient boom pressure cannot be attained, install the #2 size orifice and repeat Steps 5 through 7.
9. If a sufficient boom pressure still cannot be attained with the #2 size orifice, install the #3 size orifice and repeat Steps 5 through 7.
10. If a sufficient boom pressure still cannot be attained with the #3 size orifice, remove the orifice and repeat Steps 5 through 7.

### **Closed Center (Load Sensing) — All Models**

Many tractors are being introduced with load sensing systems (also referred to as flow and pressure-compensated systems) which simplify system setup and eliminate many of the problems associated with using the wrong size pump motors on a given hydraulic system. Usually, any of Hypro's 9300HMC models may be used on this type of system, provided the hydraulic system produces sufficient oil flow for the hydraulic motor being used (Refer to the Pump Selection Guide).

This system maintains a constant flow of hydraulic oil for a given pressure drop. The flow is adjustable with a flow control valve installed in the hydraulic system (such as the Tortoise/Hare control on John Deere tractors). Because this system has adjustable flow, there is no need to bypass hydraulic oil as in an open center system, or to restrict the flow with orifices as in a closed center pressure-compensated system.

#### **Adjusting Centrifugal Pump Output**

1. Make sure the orifice from the pressure port adapter of the hydraulic motor has been removed (HM2C and HM4C models only).
2. Close and lock down the bypass adjusting screw in the hydraulic motor.
3. Set the tractor hydraulic flow control valve for minimum hydraulic oil flow to the remote outlet (Tortoise position).
4. Start the tractor and allow the hydraulic oil to circulate for approximately 10 to 15 minutes or until adequately warmed.
5. Prime the centrifugal pump with all valves open (See the Installation Instructions and System Configuration Diagram).
6. Close the agitation line valve and open the control valve and the boom shut-off valve.
7. Slowly adjust the tractor hydraulic flow control valve until the desired boom pressure is attained.
8. Open the agitation line valve until sufficient agitation is observed. If spray pressure drops, readjust the tractor hydraulic flow control valve to restore it to the desired pressure.

#### **Flush Pump After Use**

One of the most common causes for faulty pump performance is gumming or corrosion inside the pump. Flush the pump and entire system with a solution that will chemically neutralize the liquid pumped. Mix this solution according to the manufacturer's directions. This will dissolve most residue remaining in the pump, leaving the inside of the pump clean for the next use.

#### **To Prevent Corrosion**

After cleaning the pump as directed above, flush it with a permanent-type automobile antifreeze (Prestone®, Zerex®, etc.) containing a rust inhibitor. Use a 50% solution, half antifreeze and half water. A protective coating will remain on the inner pump surfaces. Save the excess antifreeze for the next application. Plug the ports to keep out air during storage. For short periods of idleness, noncorrosive liquids may be left in the pump, but air must be kept out. Plug the ports or the seal port connections.

## Repair Instructions

### Hypro Repair Tools:

Tool Box No. 3010-0168 • 1/4" Allen Wrench No. 3020-0008  
 Support Bars (2) No. 3010-0064 • Port Brush No. 3010-0066  
 1/16" Allen Wrench No. 3020-0009 • Brush Holder No. 3010-0067 •  
 Large Retaining Ring Pliers No. 3010-0084 • Small Retaining Ring  
 Pliers No. 3010-0167

### Shop Tools Needed

Bench Vice • Arbor Press • Air or Hand Drill • Small Knife  
 Metal Pipe - 1" dia. x 4" high (Bearing Seating Tool)  
 PVC Pipe - 3/4" dia. x 4" - 6" high (Seal Seating Tool)  
 12" Crescent Wrench • Two Flat Screwdrivers (approx. 10" long)  
 1/2", 9/16", 5/8" and 7/8" sockets • Hammer or Rubber Mallet  
 Small Screwdriver (recommended) • Large File (optional)  
 1/2" and 9/16" Box End Wrench • Lubricating Spray (WD-40 or LPS)  
 Small amount Hydraulic Oil • Cleaning Solvent Tank (recommended)

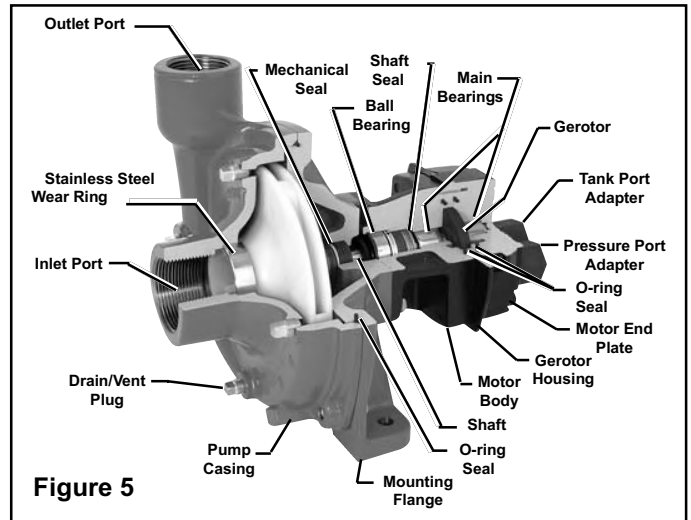

**Figure 5**

### Pump Housing Disassembly

**NOTE**

**Instructions in italics describe procedures for the Series 9300P Polypropylene Centrifugal Pumps, when different than the cast iron pumps.**

1. Using a 9/16" box end wrench, remove the four Hex Head Bolts holding the Pump Casing to the Mounting Flange. (If necessary, tap Pump Casing Outlet Port with rubber mallet or hammer to separate.) *[Using a 1/2" wrench, remove the six bolts from the front. For the two bottom bolts securing the base, you will need to hold the two nuts with another 1/2" wrench. Also remove the 5/16" screw from the rear, near the outlet port.]*
2. To remove the Impeller Nut, insert a large screwdriver or file (at least 10" [254 mm] long) into Impeller Vanes to prevent Impeller from turning when loosening nut. Use a 5/8" socket wrench to remove the Impeller Nut by turning it counterclockwise (See Figure 6). *[Use 7/8" deep socket wrench to remove Plastic Seal Nut, then 9/16" deep socket to remove Metal Jam Nut and Washer.]*

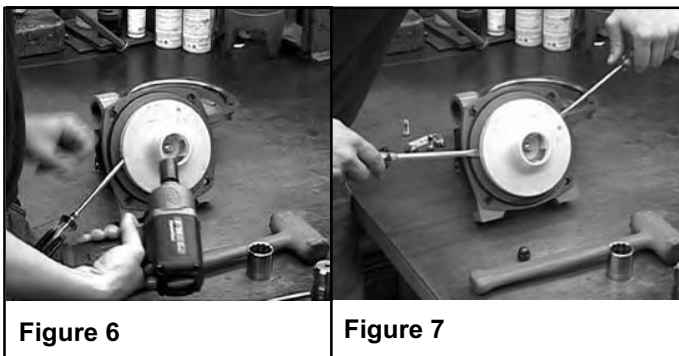

**Figure 6**

**Figure 7**

3. Once nut *[and washer]* is removed, place a screwdriver on each side behind the Impeller and pry away from the Mounting Flange (See Figure 7). Remove Woodruff Key from the Shaft. Remove O-ring from the Mounting Flange.

### Pump Seal Removal

1. Lightly lubricate the Shaft for easier removal of the Seal. Using two screwdrivers positioned opposite each other, pry the rotary portion of the Seal from the Shaft (See Figure 8).

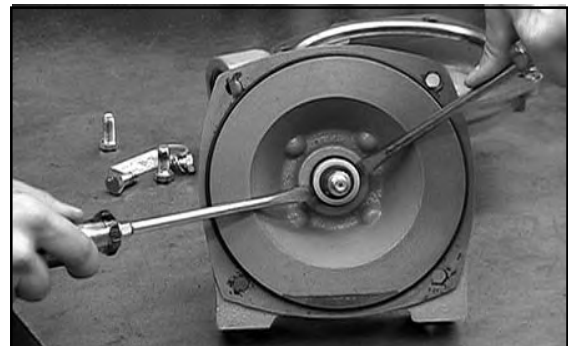

**Figure 8**

**NOTE**

**In the case of a severe pump seal leak, inspect the Shaft/Bearing Assembly in the hydraulic motor for possible contamination.**

2. Using a 1/2" box end wrench, remove the four bolts holding the Motor to the Mounting Flange. Remove Motor. *[Remove the Plastic Back Cover flange. Knock the Seal out from back with a hammer and screwdriver. Use a 1/2" socket wrench and 1/2" box end wrench to remove the Mounting Flange from the Hydraulic Motor.]*

- Using a screwdriver and hammer, tap out the stationary portion of the Mechanical Seal from the motor side of the Mounting Flange. (If the motor is not removed, the seal can be pried out with a small screwdriver.)

**NOTE**

The seal will be damaged by removal in this manner. A new seal must be used when pump is reassembled.

**Clean-Up Of Pump Housing**

- Using a circular bottle-type wire brush with air or hand drill, clean the Outlet Port, Inlet Port and the sealing areas of the o-ring on the Pump Casing and Mounting Flange. Using the port brush, clean the seal cavity in the Mounting Flange. *[The last step should not be performed on the 9300P.]*
- After wire brush cleaning, it is recommended that the Pump Casing and Mounting Flange be further cleaned in a solvent tank to remove rust and corrosion particles.

**Seal Replacement/Pump Housing Reassembly**

**NOTE**

If the hydraulic motor requires repair, proceed to Disassembly and Repair of the Hydraulic Motor in the next column.

- Lubricate the seal cavity in the Mounting Flange with WD-40®, LPS or equivalent. Do not lubricate the shaft.
- Install the stationary portion of the Mechanical Seal by sliding over the Shaft with the ceramic side out.

**NOTE**

Make sure both the seal cavity and seal are clean and lubricated.

- To seat the seal in the seal cavity, use a piece of 3/4" PVC pipe 4" to 6" [101.6 to 152.4 mm] in length. Lubricate sealing surface on seal after it is seated. Do not lubricate the shaft.
- To install the rotary portion of the mechanical seal, place it over the shaft with the carbon side facing in, and press against the stationary portion (See Figure 9).
- Install rubber gasket 1700-0100 over shaft against rotary portion of seal.



Figure 9

**NOTE**

On Models 9305C-HM3C-SP, 9505C-HM3C-BS and 9305C-HM3C, install the washer on the shaft prior to installing the impeller nut.

**CAUTION**

The threads of the Plastic Seal Nut are fine and can be easily cross threaded. To prevent cross threading, turn the Plastic Seal Nut counterclockwise until area of thread engagement is detected; then turn the Plastic Seal Nut clockwise until it is secure. Do not over tighten the Plastic Seal Nut.

- Insert a Woodruff Key into the Shaft key slot; then place the Impeller on the Shaft and align it with the Key and press against the Mechanical Seal Assembly. Apply a blue thread locking compound to the Impeller Nut, and using a 5/8" socket wrench and using a screwdriver to hold the Impeller, install the Impeller Nut. *[On polypropylene models, insert the Woodruff Key into the Shaft key slot. Place the Impeller on the Shaft and align it with the Key; then press against the Mechanical Seal Assembly. Place the Metal Seal Washer on the Shaft. Apply a drop of blue thread locking compound on the Impeller Nut and secure the Impeller to the Shaft as described previously.]*
- Install the o-ring on the mounting flange. Replace the o-ring if worn or damaged.
- Place the pump casing on the mounting flange, insert and tighten the bolts.

**Disassembly and Repair of the Hydraulic Motor**

**NOTE**

The work area and motor should be as clean as possible to prevent contamination of parts.

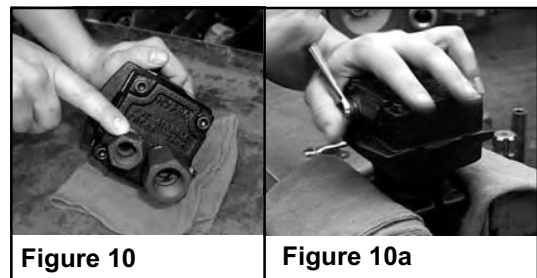

Figure 10

Figure 10a

- Remove the Mounting Flange from the motor body and place Hydraulic Motor in vise.
- Remove Tank Port Adapter and Pressure Port Adapter with large crescent wrench or 1-1/16" and 1-3/8" box end wrench (See Figure 10).
- Using a 9/16" box end wrench, loosen the nut on the Bypass Adjusting Screw (See Figure 10a).
- Using a small screwdriver, remove the Bypass Adjusting Screw from the Motor. (This will remove the Screw, Nut, Washer and Thread-Seal Gasket.)
- Using a 1/4" Allen wrench, remove the Socket Head Cap Screws from the Motor End Plate (See Figure 10).
- If Motor End Plate will not lift off easily, use a small screwdriver to carefully pry apart the boss portion of the End Plate and Gerotor Housing until free (See Figure 11). If Gerotor Housing will not lift off easily, carefully pry

apart the boss area between the Gerotor Housing and the Motor Body. (It may be necessary to alternate sides when prying apart Motor sections.)



Figure 11

7. Remove both parts of the Gerotor.
8. On HM3C models, remove the Woodruff Key from the Shaft. On HM1C, HM2C and HM4C models, remove the Roll Pin from the Shaft.
9. Remove the o-ring from the Motor End Plate and Body with a flat instrument such as a knife blade.
10. Inspect Motor End Plate, Body and Gerotor Housing for wear and/or gouging. If gouging has occurred in both the Motor End Plate and Body, the motor is not repairable. If gouging has occurred in the Motor End Plate, Body or Gerotor Housing, the part that is worn must be replaced. If Gerotor Housing is damaged, Gerotor parts must also be replaced.

**To Remove the Shaft Assembly from the Motor Body**

1. Remove the Slinger Ring from the Motor Shaft.

**⚠ WARNING**

**Special attention should be exercised when working with retaining rings. Always wear safety goggles when working with spring or tension loaded fasteners or devices.**

2. Using the large retaining ring pliers, remove the Retaining Ring next to the Ball Bearing in the Motor Body.

**NOTE**

**If bearing is binding against the retaining ring so that it cannot easily be removed, place the motor body (threaded portion of the shaft up) on arbor press. Using a piece of un-threaded metal pipe (1" dia. x 4" high [254. mm x 101.6 mm high]), slide over the shaft and gently press down with the arbor press just enough to relieve the pressure on the retaining ring.**



Figure 12

3. Place body in position on arbor press. Threaded portion of the Shaft should be inside the fixture. Press out shaft assembly with arbor press (See Figure 12).

**Hydraulic Motor Shaft Disassembly and Repair**

1. Remove Large Retaining Ring from Shaft with a screwdriver. Remove Thrust Bearing Assembly from Shaft (includes the Thrust Bearing and two Thrust Bearing Races) and the Seal Spacer.
2. Remove the Small Retaining Ring next to the Shaft Ball Bearing.
3. To remove the Bearing from the shaft, place the shaft (threaded end up) in the arbor press fixture. Place the two support bars provided in the repair kit opposite each other and between the seal on the shaft and the arbor press fixture. Using an arbor press, press the shaft through the Bearing, Seal Spacer and Seal (See Figure 13).
4. Inspect the sealing area of the shaft for wear. Inspect other Shaft Assembly Components for wear and replace if necessary.



Figure 13

5. While motor is completely disassembled, clean all parts in a solvent bath.

**Build Shaft Sub-Assembly**

1. To assemble the seal cartridge, remove the old seal from the cartridge by pressing it out. The cartridge is reused by assembling the new seal into cartridge, ensuring the new seal is pressed in with the lip seal on the opposite side as shown in Fig.1.

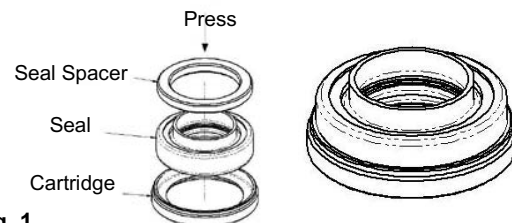

Fig. 1

**Important:** To prevent damage to the seal lip extending out, use seal spacer as shown to guard lip during assembly.

2. Install the large retaining ring onto large diameter end of shaft.
3. From the small, threaded end of the shaft, install the following parts in this order: thrust bearing race, thrust bearing, 2nd thrust bearing race.

**Note:** The thrust bearing and races should not be reused if they are showing any signs of wear.

4. Install new type seal spacer (looks like a thick washer, approx .130 inch thick).
5. Before installing the new seal, its lip must be expanded to fit on the shaft. With the seal lip facing out, slide the seal over the threaded end of the shaft and gently push the seal onto the raised area of the shaft. Do not push the seal past the large retaining ring groove on the shaft.

6. Once the seal has been expanded, remove the seal from the shaft.
7. Install seal cartridge assembly: With seal lip facing the large end of the shaft, slide the seal cartridge assembly over the threaded end of the shaft and gently push into the raised area of the shaft. Align the seal lip to enter the center diameter of the seal spacer and push until seal body touches seal spacer.

**Important:** If the seal lip is longer than the seal spacer's width, please stop the assembly and review parts being used.

8. Assemble two o-rings on the outside body of the new seal cartridge assembly as shown in Fig 2. Install o-rings one at a time and do not roll over each other.

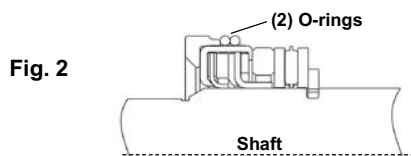

Fig. 2

9. Finished shaft sub-assembly should look like this:



10. Do not press, but place the shaft sub-assembly into the motor body with threaded end of shaft up. Lubricate the two o-rings with hydraulic or mineral oil before assembling.



Figure 14

### Install Shaft Sub-Assembly Into Motor Body

**Important:** Make sure the surface edge of the arbor press fixture is smooth and clean. An unthreaded piece of pipe (1" x 4" high) is needed to support the outer race of the seal cartridge sub-assembly and outer race of the ball bearing during assembly. Place this pipe over the shaft threaded end for assembly of the following steps.

1. Place the body on a support fixture in the arbor press. Using an unthreaded piece of pipe (1" dia. x 4" high), press the shaft subassembly down into the body until it bottoms out. This is a light press fit and should be done slow and easy.

2. Install the new ball bearing onto the threaded end of the shaft. Press down using the 1" x 4" pipe until the retaining ring can be installed in its groove in the bearing core of the motor body. Install the retaining ring.



Figure 15

3. Turn the motor body assembly over (threaded shaft end down) on the arbor press. Press the shaft down into its "final position" until the small retaining ring can be installed in the shaft next to the ball bearing.
4. Install small retaining ring on shaft.
5. Check shaft rotation at this point. It should rotate smoothly with only slight resistance from the seal lip pressure on the shaft. If you feel any gritty or sticking movement, return assembly to the arbor press and lightly press on the threaded end of the shaft to relieve press fit compression on the thrust bearing. **Note:** Don't over do this press. The objective is to move the small outer retaining ring installed in the previous step back to "touching only" the ball bearing inner race.

**Important:** If gritty or sticky movement persists, it's likely due to re-used parts or the body needle bearing is in need of replacement.

### Reassembly of Remaining Hydraulic Motor Parts

1. Place Motor Body in a vise with large end of shaft facing up.
2. Install the o-ring in the body.
3. Install the Roll Pin on the shaft. Place the Inner Gear of the Gerotor onto the shaft making sure Gerotor slot lines up with the key in the shaft.

**The Roll Pin can slide up behind the inner gear of the gerotor when the gear is installed. Make sure the key is visible in the slot after the gear is in place.**

4. Install the outer portion of the Gerotor, making sure the Gerotor is centered within the o-ring groove on the body.
5. Install the Gerotor Housing, making sure the pins in the Gerotor Housing line up with their respective holes in the body.

6. Lightly lubricate the area between the Inner and Outer Gerotor, the Outer Gerotor, and Gerotor Housing with hydraulic oil or mineral oil.

**Special attention should be exercised when working with retaining rings. Always wear safety goggles when working with spring or tension-loaded fasteners or devices.**

7. Install o-ring on the motor end plate.
8. Place end plate on gerotor housing, making sure holes in end plate line up with pins in the gerotor housing.
9. Install four Socket Head Cap Screws in Motor End Plate, and using a 1/4" Allen wrench, tighten Cap Screws alternately and evenly in a crisscross pattern to approximately 15 foot pounds [ 20 Nm] of torque.
10. Install the Thread Seal Gasket on the Bypass Adjusting Screw. Put the Gasket on from the slotted end and turn until four threads on the screw are showing. Install the Washer and the Nut. Install Bypass Adjusting Screw in the motor end plate.
  - A. For closed center hydraulic systems, turn the Bypass Adjusting Screw in until it bottoms out in the End Plate. Tighten nut down with 9/16" box end wrench.

- B. For open center hydraulic systems, turn the Bypass Adjusting Screw in until it bottoms out in the End Plate; then turn back out 1½ full turns. Holding the Bypass Adjusting Screw with a screwdriver, tighten Nut. (Motor will then have to be readjusted to tractor system.)

11. Replace o-ring on both port adapters.
12. Install Pressure Port Adapter and Tank Port Adapter back onto the motor. (For ease of installation, tighten the Pressure Port Adapter first, then the Tank Port Adapter.)
13. Remove Hydraulic Motor from the vise. Turn shaft by hand to check for binding.
14. Install Slinger Ring over Motor Shaft.
15. Install Motor into Pump Mounting Flange. Insert four Hex Head Bolts; then alternately and evenly tighten them. *[For polypropylene models, secure the Hydraulic Motor to the Mounting Flange with four Hex Head Cap Screws and Nuts. The nuts should be visible when the assembly is complete.]*

## Troubleshooting

If the proper Hydraulic Pump Unit has been selected according to Hypro recommendations, and the unit has been correctly plumbed into the hydraulic system, operation should be quite satisfactory. If spraying performance is unsatisfactory

or hydraulic system heat is excessive etc., check the following troubleshooting guide for possible problems and solutions.

### Troubleshooting Guide

Symptom	Probable Cause(s)	Corrective Action(s)
Low discharge	Pump not primed.	— Remove top most vent plug from face of pump and run pump to expel trapped air (see Installation Instructions).
	Air leaks in inlet line.	— Check and reseal inlet fittings.
	Blocked or clogged line strainer.	— Inspect strainer and clear any debris from screen.
	Impeller plugged.	— Inspect and clear obstruction.
	Undersize inlet line or collapsed hose.	— Suction line should be the same diameter as inlet port of pump or larger.
	Improperly sized hydraulic motor.	— Refer to Pump Selection Guide to determine proper size hydraulic motor for your hydraulic system.
	Bypass Adjustment Screw not set properly.	— Adjust bypass screw on side of hydraulic motor in until the desired output is attained.
Hydraulic system overheating	Eye of impeller rubbing on volute.	— Remove volute (front cover) and inspect the impeller. If wear detected, sand the impeller eye O.D. with emery cloth.
	Improper hydraulic motor size.	— Refer to Pump Selection Guide to determine proper size for your hydraulic system.
Hydraulic system overheating	Bypass Adjustment Screw set to bypass too much oil.	— Close adjustment screw on side of hydraulic motor to lessen the amount of oil being bypassed.
	Improper metering orifice installed in pressure port.	— Install proper size orifice. Refer to Installation section for proper sizing.
	Insufficient hydraulic hose size.	— Check hydraulic hose size. Hose should be at least 1/2" [12.7 mm] on the pressure port and 3/4" [19.05mm] on the tank port.



All 9303C and 9303S Series Pumps

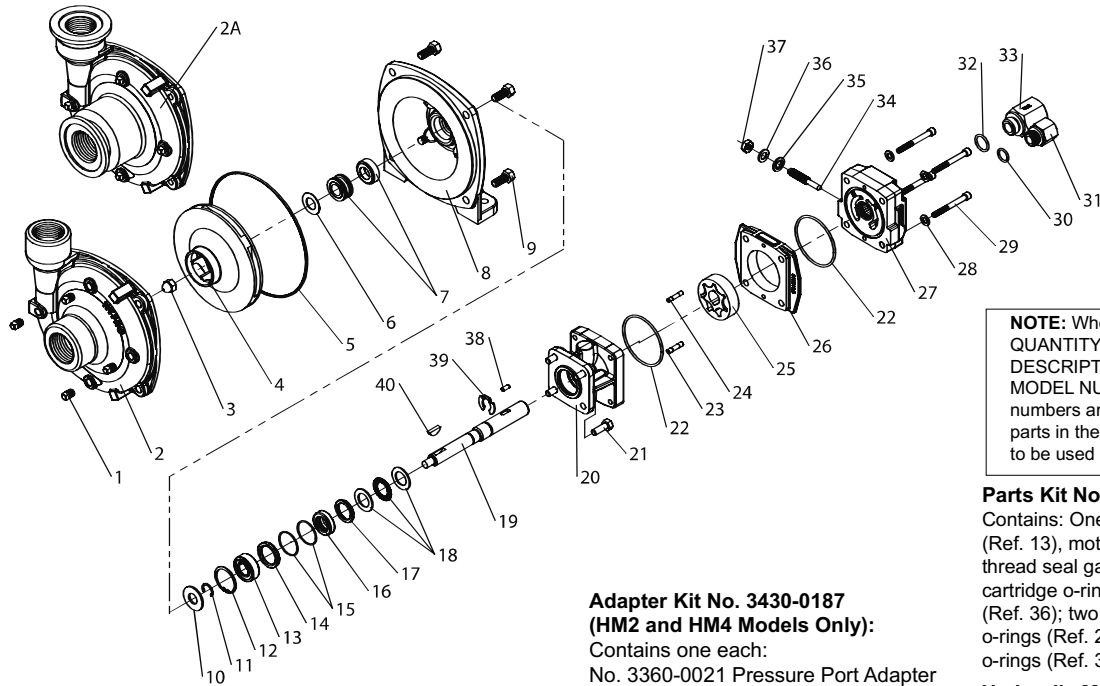

**Repair Parts Kit No. 3430-0332**  
 Contains: One o-ring (Ref. 5), one rubber gasket (Ref. 6), and one mechanical seal (Ref. 7).

**Silicon Seal Kit No. 3430-0589**  
 Contains one each: 1720-0083 o-ring (Ref. 5) and one mechanical seal (silicon carbide) (Ref.7).

**Adapter Kit No. 3430-0187 (HM2 and HM4 Models Only):**  
 Contains one each:  
 No. 3360-0021 Pressure Port Adapter  
 No. 3373-0020 (Size #1)  
 No. 3373-0021 (Size #2)  
 No. 3373-0022 (Size #3).  
 No. 1720-0108 Adapter O-ring and  
 No. 1720-0105 Orifice O-ring (Qty 3).

**NOTE:** When ordering parts, give QUANTITY, PART NUMBER, DESCRIPTION, and COMPLETE MODEL NUMBER. Reference numbers are used ONLY to identify parts in the drawing and are NOT to be used as order numbers.

**Parts Kit No. 3430-0748**  
 Contains: One each ball bearing (Ref. 13), motor shaft seal (Ref. 16), thread seal gasket (Ref. 35), two cartridge o-rings (Ref. 15) and washer (Ref. 36); two each motor housing o-rings (Ref. 22), and port adapter o-rings (Ref. 30 & 32).

**Hydraulic Motor Part Nos.**  
 2500-0081C (HM1C Models)  
 2500-0082C (HM2C Models)  
 2500-0083C (HM3C Models)  
 2500-0084C (HM4C Models)  
 2500-0085C (HM5C Models)

Ref. No.	Qty. Req'd.	Part No.	Description
1	4	2406-0007	Drain/Vent Plug (9303C)
1	4	2406-0016	Drain/Vent Plug (9303S)
2	1	0150-9000C	Pump Casing (Model 9303C)
2	1	0150-9000S	Pump Casing (Model 9303S)
2A	1	0153-9000C	Pump Casing (Universal Flange Model C-U)
3	1	2253-0002	Impeller Nut (9303C)
3	1	2253-0006	Impeller Nut (9303S)
4	1	0401-9100P	Impeller (Nylon Std. 9303C)
4	1	0402-9100P	Impeller (Polypropylene Optional) (Std 9303S)
5	1	1720-0083	O-ring
6	1	1700-0100	Gasket
7	1	2120-0009	Mechanical Seal (Viton/Ceramic) (Std 9303C)
7	1	3430-0589	Mechanical Seal (Silicon Carbide) (Std 9303S)
8	1	0750-9300C	Mounting Flange (9303C)
8	1	0756-9300S	Mounting Flange (9303S)
9	4	2210-0020	Hex Head Cap Screw (9303C)
9	4	2210-0125	Hex Head Cap Screw (9303S)
10	1	1410-0056	Slinger Ring
11	1	1810-0014	Snap Ring
12	1	1820-0013	Retaining Ring
13	1	2000-0010	Ball Bearing
14	1	1410-0131	Cartridge, Front
15	2	1720-0268	O-ring
16	1	2104-0010	Lip Seal
17	1	1410-0130	Seal Spacer
18	1	2029-0014	Thrust Bearing Assembly
19	1	0531-2500	Shaft (HM2C/HM4C)
19	1	0533-2500	Shaft (HM1C/HM5C)
19	1	0536-2500	Shaft (HM3C)
20	1	0150-2500C	Motor Body (includes needle bearing)
21	4	2210-0005	Hex Head Cap Screw
22	2	1720-0110	O-ring
23	1	1600-0045	Dowel Pin (HM2C / HM4C)
23	1	1600-0044	Dowel Pin (HM1C/HM5C)
23	1	1600-0052	Dowel Pin (HM3C)

Ref. No.	Qty. Req'd.	Part No.	Description
24	1	1600-0042	Dowel Pin (HM2C / HM4C)
24	1	1600-0037	Dowel Pin (HM1C/HM5C)
24	1	1600-0068	Dowel Pin (HM3C)
25	1	3900-0022	Gerotor (HM1C)
25	1	3900-0023	Gerotor (HM2C)
25	1	3900-0024	Gerotor (HM3C)
25	1	3900-0025	Gerotor (HM4C)
25	1	3900-0048	Gerotor (HM5C)
26	1	0701-2500C1	Gerotor Housing (HM2C Models) 1/4" wide
26	1	0700-2500C1	Gerotor Housing (HM1C Models) 1/2" wide
26	1	0703-2500C1	Gerotor Housing (HM4C Models) 5/16" wide
26	1	0702-2500C1	Gerotor Housing (HM3C Models) 1" wide
26	1	0704-2500C1	Gerotor Housing (HM5C Models) 5/8" wide
27	1	0254-2500C2	Motor End Plate (includes needle bearing)
28	4	2270-0039	Washer
29	4	2220-0045	Cap Screw (HM2C / HM4C Models)
29	4	2220-0021	Cap Screw (HM1C Models)
29	4	2220-0044	Cap Screw (HM3C Models)
29	4	2220-0032	Cap Screw (HM5C Models)
30	1	1720-0108	O-ring
31	1	3360-0021A	Pressure Port Adapter (includes o-ring)
32	1	1720-0262	O-ring
33	1	3320-0051A	Tank Port Adapter (includes o-ring)
34	1	3220-0029	Bypass Adjusting Screw
35	1	1700-0047	Gasket
36	1	2270-0027	Washer
37	1	2250-0038	Lock Nut
38	1	1610-0032	Roll Pin (HM2C / HM4C)
38	1	1610-0031	Roll Pin (HM1C / HM5C)
38	1	1610-0055	Roll Pin (HM3C)
39	1	1810-0026	Snap Ring
40	1	1610-0012	Woodruff Key (9303C)
40	1	04432	Woodruff Key (9303S)

All 9306C Series

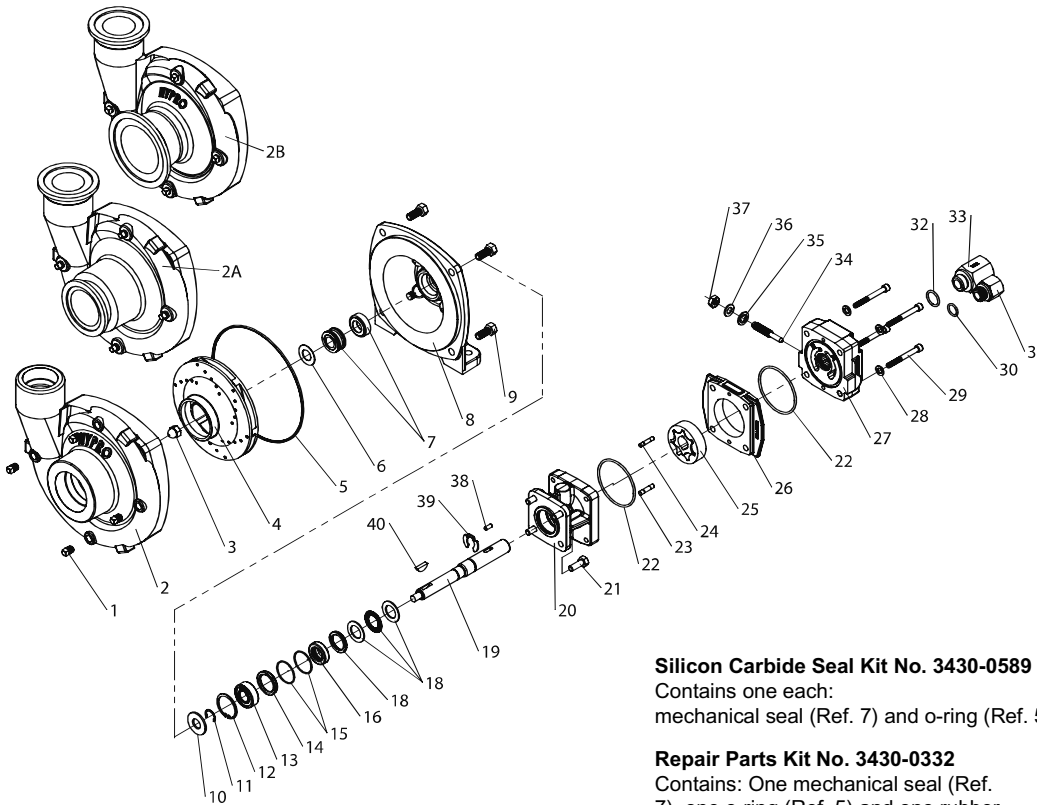

**NOTE:** When ordering parts, give QUANTITY, PART NUMBER, DESCRIPTION, and COMPLETE MODEL NUMBER. Reference numbers are used ONLY to identify parts in the drawing and are NOT to be used as order numbers.

- Parts Kit No. 3430-0748**  
 Contains: One each ball bearing (Ref. 13), motor shaft seal (Ref. 16), thread seal gasket (Ref. 35), two cartridge o-rings (Ref. 15) and washer (Ref. 36); two each motor housing o-rings (Ref. 22), and port adapter o-rings (Ref. 30 & 32).
- Silicon Carbide Seal Kit No. 3430-0589**  
 Contains one each: mechanical seal (Ref. 7) and o-ring (Ref. 5).
- Repair Parts Kit No. 3430-0332**  
 Contains: One mechanical seal (Ref. 7), one o-ring (Ref. 5) and one rubber gasket (Ref. 6).
- Hydraulic Motor Part Nos.**  
 2500-0081C (HM1C Models)  
 2500-0083C (HM3C Models)  
 2500-0085C (HM5C Models)

Ref. No.	Qty. Req'd.	Part No.	Description
1	4	2406-0007	Drain/Vent Plug (9306C)
1	4	2406-0016	Drain/Vent Plug (9306S)
2	1	0154-9200C1	Pump Casing (9306C)
2	1	0154-9200S1	Pump Casing (9306S)
2A	1	0157-9200C	Pump Casing (Universal Flange 220x200)
2B	1	0158-9200C	Pump Casing (Universal Flange 300x220 Cast)
2B	1	0158-9200S	Pump Casing (Universal Flange 300x220 S.S.)
3	1	2253-0002	Impeller Nut (9306C)
3	1	2253-0006	Impeller Nut (9306S)
4	1	0401-9200P2	Impeller (Nylon Std. 9306C)
4	1	0405-9100P2	Impeller (Polypropylene Optional) (Std. 9306S)
4	1	0407-9306P	Impeller (GTX Optional)
5	1	1720-0083	O-ring
6	1	1700-0100	Gasket
7	1	2120-0009	Mechanical Seal (Viton/Ceramic) (Std. 9306C)
7	1	3430-0589	Mechanical Seal (Silicon Carbide) (Std. 9306S)
8	1	0750-9300C2	Mounting Flange (9306C)
8	1	0756-9300S	Mounting Flange (9306S)
9	4	2210-0020	Hex Head Cap Screw (9306C)
9	4	2210-0125	Hex Head Cap Screw (9306S)
10	1	1410-0056	Slinger Ring
11	1	1810-0014	Snap Ring
12	1	1820-0013	Retaining Ring
13	1	2000-0010	Ball Bearing
14	1	1410-0131	Cartridge, Front
15	2	1720-0268	O-ring
16	1	2104-0010	Lip Seal
17	1	1410-0130	Seal Spacer
18	1	2029-0014	Thrust Bearing Assembly
19	1	0531-2500	Shaft (HM2C/HM4C)
19	1	0533-2500	Shaft (HM1C/HM5C)
19	1	0536-2500	Shaft (HM3C)
20	1	0150-2500C	Motor Body (includes needle bearing)
21	4	2210-0005	Hex Head Cap Screw
22	2	1720-0110	O-ring

Ref. No.	Qty. Req'd.	Part No.	Description
23	1	1600-0045	Dowel Pin (HM2C / HM4C)
23	1	1600-0044	Dowel Pin (HM1C/HM5C)
23	1	1600-0052	Dowel Pin (HM3C)
24	1	1600-0042	Dowel Pin (HM2C / HM4C)
24	1	1600-0037	Dowel Pin (HM1C/HM5C)
24	1	1600-0068	Dowel Pin (HM3C)
25	1	3900-0022	Gerotor (HM1C)
25	1	3900-0023	Gerotor (HM2C)
25	1	3900-0024	Gerotor (HM3C)
25	1	3900-0025	Gerotor (HM4C)
25	1	3900-0048	Gerotor (HM5C)
26	1	0701-2500C1	Gerotor Housing (HM2C Models) 1/4" wide
26	1	0700-2500C1	Gerotor Housing (HM1C Models) 1/2" wide
26	1	0703-2500C1	Gerotor Housing (HM4C Models) 5/16" wide
26	1	0702-2500C1	Gerotor Housing (HM3C Models) 1" wide
26	1	0704-2500C1	Gerotor Housing (HM5C Models) 5/8" wide
27	1	0254-2500C2	Motor End Plate (includes needle bearing)
28	4	2270-0039	Washer
29	4	2220-0045	Cap Screw (HM2C / HM4C Models)
29	4	2220-0021	Cap Screw (HM1C Models)
29	4	2220-0044	Cap Screw (HM3C Models)
29	4	2220-0032	Cap Screw (HM5C Models)
30	1	1720-0108	O-ring
31	1	3360-0021A	Pressure Port Adapter (includes o-ring)
32	1	1720-0262	O-ring
33	1	3320-0051A	Tank Port Adapter (includes o-ring)
34	1	3220-0029	Bypass Adjusting Screw
35	1	1700-0047	Gasket
36	1	2270-0027	Washer
37	1	2250-0038	Lock Nut
38	1	1610-0032	Roll Pin (HM2C / HM4C)
38	1	1610-0031	Roll Pin (HM1C / HM5C)
38	1	1610-0055	Roll Pin (HM3C)
39	1	1810-0026	Snap Ring
40	1	1610-0012	Woodruff Key (9306C)
40	1	04432	Woodruff Key (9306S)



