

REFERENCE GUIDE

EZ-Steer® 500 Assisted Steering System

Version 2.00

Revision B

June 2009

Part Number 66024-80-ENG

Table of Contents

Legal Notices.....	1
Copyright.....	1
Safety.....	2
Introduction.....	2
Care of the System.....	2
European Highway Usage.....	2
Cautions.....	2
Introduction.....	4
About the System.....	4
Getting Started.....	5
EZ–Steer 500 Kit Contents.....	5
Pre–Installation Vehicle Inspection.....	6
Worn Components.....	6
Wheel Problems.....	8
Electrical Problems.....	9
Hydraulic Fluid.....	10
Installation.....	12
Installation Process.....	12
STEP 1: Installing the motor with the platform.....	12
STEP 2: Installing the controller.....	12
STEP 3: Mounting the GPS antenna.....	13
STEP 4: Connecting optional switches.....	15
STEP 5: Connecting the components.....	18
Calibration.....	19
Introduction.....	19
EZ–Steer Calibration Wizard Process.....	19
Before Starting the EZ–Steer Calibration Wizard.....	19
STEP 1: Starting the EZ–Steer Calibration Wizard.....	20
STEP 2: Entering the Vehicle Settings.....	20
STEP 3: Completing T2 Roll Calibration.....	23
STEP 4: Calibrating EZ–Steer 500 System Settings.....	25
STEP 5: Confirming the Calibration Parameters.....	28
Using The EZ–Steer System.....	29
Introduction.....	29
Screen Items.....	29
Engage Status Indication.....	29
Engaging.....	30
Disengaging.....	30
Curve Autosteering Accuracy.....	31
Engage Options (Advanced Mode Only).....	31
Vehicle–Specific Performance Hints.....	31

Table of Contents

Troubleshooting	33
Introduction.....	33
General.....	33
General GPS.....	34
System Performance.....	35
Messages And Faults	38
EZ–Steer 500 System Disengaged Warning.....	38
T2 Technology System Warning Messages.....	39
EZ–Steer System Fault Codes.....	39
Maintenance	42
Maintenance Schedule.....	42
Pivot Bearing Maintenance.....	42
Appendix A	46
Introduction.....	46
Vehicle Speed Limits.....	46
Operating Limits.....	46

Legal Notices

Copyright

(c) 2007, Trimble Navigation Limited. All rights reserved.

AgGPS, EZ–Guide, and EZ–Steer are trademarks of Trimble Navigation Limited, registered in the United States Patent and Trademark Office and in other countries. Autopilot, OnPath, and T2 are trademarks of Trimble Navigation Limited.

All other trademarks are the property of their respective owners.

For Limited Warranty information, refer to the *EZ–Steer 500 System Release Notes*.

Safety

Introduction

Always follow the instructions that accompany a Caution. The information it provides is intended to minimize the risk of personal injury and/or damage to property. In particular, observe safety instructions that are presented in the following format:

CAUTION – This alert warns of a hazard or unsafe practice which, if not avoided, can cause injury or damage.

Note – An absence of specific alerts does not mean that there are no safety risks involved.

Care of the System

To maximize the life expectancy of the foam drive wheel, as soon as you finish using the system, hinge the electric motor until it locks in the "away" position.

When you are not going to use the EZ–Steer 500 system for a long period of time, remove the EZ–Steer 500 motor from the vehicle and store it in a dry location to prevent damage from condensation and other moisture.

European Highway Usage

You must remove the motor assembly from the mounting bracket prior to driving the vehicle on a public highway. To remove the motor, undo the two thumb screws.

Cautions

CAUTION – This manual relates to the EZ–Steer 500 system when used with the EZ–Guide 500 system. It should not be used with the EZ–Guide Plus system. If you have an EZ–Steer system connected to an EZ–Guide Plus system, refer to the EZ–Steer System for the EZ–Guide Plus Lightbar Reference Guide.

CAUTION – For continued protection against the risk of fire, replace each of the fuses only with same type and rating of fuse.

CAUTION – Always hold the steering wheel while you adjust the column tilt. Otherwise, the weight of the motor may cause the steering wheel drop suddenly and cause damage to the steering column or dash.

CAUTION – Articulated tractors pivot in the middle. Avoid putting yourself in a position where you could be injured by the pivoting rear section of the vehicle.

CAUTION – Do not attach the controller to a rear window because vibration in this location can cause the controller to output false terrain compensation readings that could affect performance and cause the vehicle to swerve offline.

CAUTION – Mount the controller as solidly as possible using the supplied mounting plate. If the controller is able to move, or if objects bump it, the controller may make false terrain compensation readings that could affect performance and cause the vehicle to swerve offline.

CAUTION – The EZ–Steer 500 system is not designed to be mounted on machines with an open operator's station (no enclosed operator's cab). Doing so will void the warranty of the EZ–Steer 500 system components.

CAUTION – Ensure that you mount the antenna so that it is level. If the antenna is not level, GPS performance may be reduced.

CAUTION – Make changes to the system settings in incremental steps. Random changes are likely to result in poor performance.

CAUTION – If you increase the value in the Disengage Offline. field, the vehicle may overshoot the corners by at least a few feet.

CAUTION – Ensure that the antenna offset measurement is accurate to within 7.6 cm (3 inches). An incorrect offset can cause the vehicle to swerve offline or oscillate back and forward and may cause damage to the vehicle or other property.

CAUTION – Do not supply voltages greater than 16 VDC to the EZ–Steer 500 system, or you risk permanently damaging it.

Introduction

About the System

The EZ-Steer® 500 assisted steering system steers the vehicle down field passes using GPS guidance from the EZ-Guide® 500 lightbar guidance system, a controller, and a motor mounted to the steering column of the vehicle.

CAUTION – This manual relates to the EZ-Steer 500 system when used with the EZ-Guide 500 system. It should not be used with the EZ-Guide Plus system. If your EZ-Steer system is connected to an EZ-Guide Plus system, refer to the *EZ-Steer System for the EZ-Guide Plus Lightbar Reference Guide*.

For the latest EZ-Steer 500 system information, go to <http://www.EZ-Steer.com/>.

An EZ-Steer controller contains T2 terrain compensation technology sensors that detect the angle and speed of changes to correct the following errors:

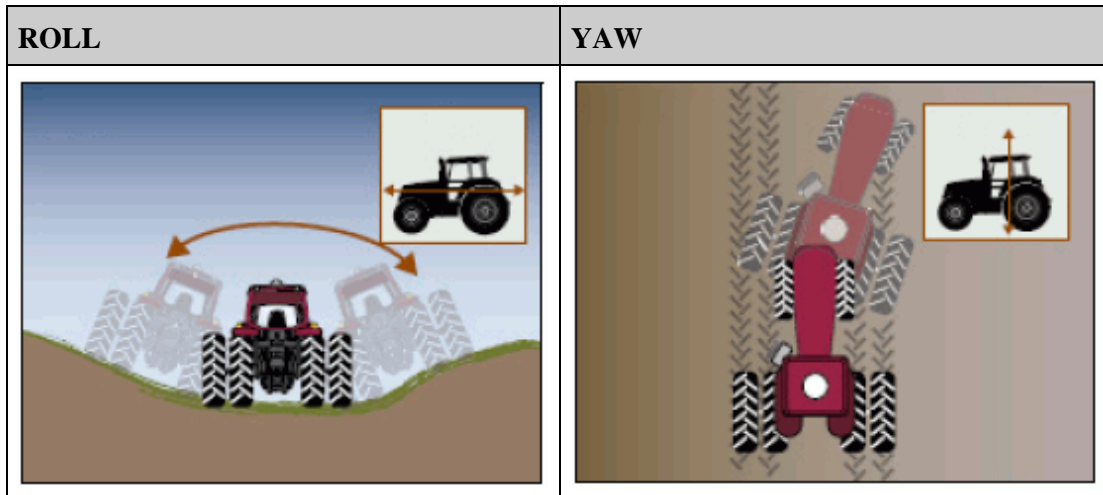

Terrain compensation can significantly improve accuracy on slopes, large bumps, and ditches, and can make steering much smoother.

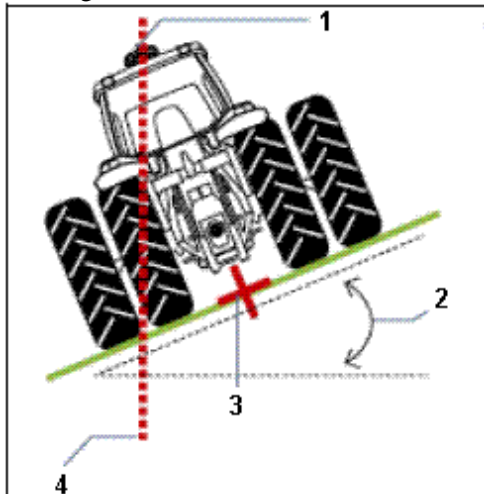

ITEM	DESCRIPTION
1	AgGPS antenna
2	Roll angle
3	Position corrected by T2 technology
4	Position without terrain compensation



The EZ–Steer 500 system is designed to provide better performance than a human driver. For sub–inch accuracy for spreading, spraying, cultivation, and broadacre planting, use the AgGPS® Autopilot automated steering system.

Getting Started

Follow the process below to get started with the EZ–Steer 500 system.

1. Perform a pre–installation vehicle inspection — see Chapter 2.
2. Install the system — see Chapter 3.
3. Set up and calibrate the system — see Chapter 4.

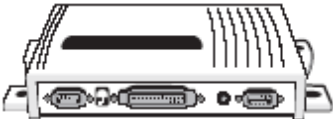
EZ–Steer 500 Kit Contents

CONTROLLER	MOTOR	CABLING
		

Note – If you choose to purchase this kit, a platform kit is also required.



Optional Accessories



In addition to the EZ–Steer 500 system kit and platform kit, you can purchase any of the following optional accessories:

- Seat switch to prevent engaging when the operator is not in the seat or to cause the system to disengage when the operator leaves the seat
- Remote engage foot pedal

Pre-Installation Vehicle Inspection

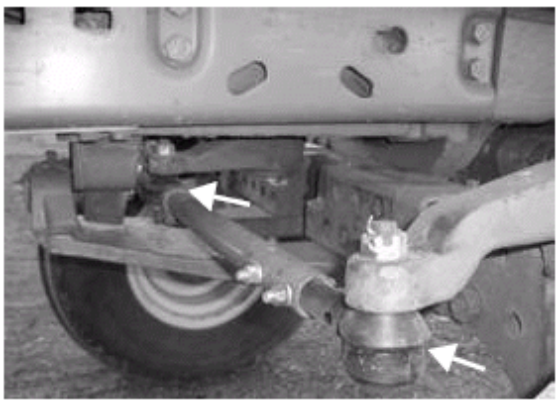

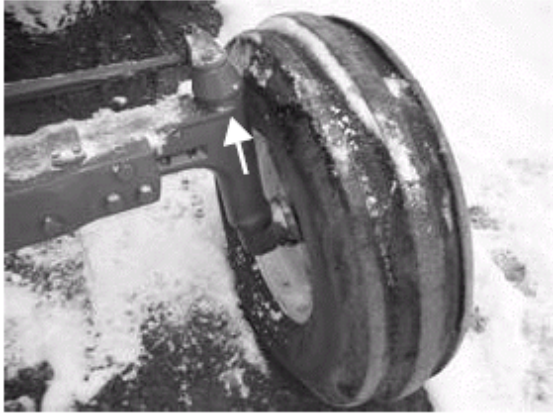
Worn Components



PROBLEM	CAUSE/SOLUTION	PHOTO
<p>Worn paint around linkage connection points</p>	<p>The bolt has been loose in the connecting arm hole; this indicates a bad ball joint. Replace the ball joint.</p>	
<p>Worn ball joints</p>	<p>The rubber boot seal is missing. Exposure to water and dirt increases the likelihood of a worn ball joint. To check if the ball joint is loose, turn the steering wheel in short, quick motions left and right.</p> <p><i>Note – If your tractor has had a front loader attached, it will almost always have worn ball joints. Replace the ball joints.</i></p>	
<p>Torn rubber boot seal around ball joint from poor lubrication</p>	<p>To check if the ball joint is loose, turn the steering wheel in short, quick motions left and right.</p> <p>Check the inner and outer tie rod ball joints for problems.</p> <p>If the ball joint moves a small distance before the connecting arm turns, replace the ball joint.</p>	

<p>Worn splines</p>	<p>In some 2WD tractors, the connecting arm is bolted onto a splined wheel hub shaft. Turn the steering wheel with short, quick motions left and right. The connecting arm should move immediately with the wheel.</p> <p>If you notice a small amount of connecting arm movement before the wheel turns, it is likely that the splines are worn.</p> <p>Replace the front wheel hub shaft.</p>	
<p>Worn front axle pivot pin bushing</p>	<p>On MFWD tractors with a rigid front axle, turn the steering wheel and watch the front wheels turn. If the axle moves forward or backward as you turn the steering wheel (see the white arrows), replace the axle pivot pin bushing.</p>	
<p>Worn steering cylinder pins and bushings</p>	<p>On articulated 4WD tractors, turn the steering wheel and check for play in the steering cylinder pins.</p> <p>If you can see either of the cylinder rods move slightly before the tractor starts to hinge left or right, you must replace the pins and bushings.</p> <p>CAUTION – Articulated tractors pivot in the middle. Avoid putting yourself in a position where you could be injured by the pivoting rear section of the vehicle.</p>	

<p>Worn steering shaft causes loose steering wheel</p>	<p>A steering column with play in all directions (see white arrows) can cause the steering shaft to bind against its housing when the pressure of the EZ-Steer motor is applied, making it difficult for the EZ-Steer motor to turn the wheel.</p> <p>Repair or replace the steering shaft.</p>	
--	---	--

Wheel Problems

PROBLEM	CAUSE/SOLUTION	PHOTO
<p>Uneven tire pressure</p>	<p>Tires mounted on the same axle must be inflated to the same pressure. This improves machine stability by preventing cab roll, and reduces the effort required to turn the front wheels.</p> <p>If the tractor front tires are filled with a fluid such as calcium chloride, slightly increase the Aggressiveness setting in the EZ-Steer 500 system.</p>	
<p>Telescope lock does not hold column in place</p>	<p>For some tractors, you may need to clamp a bracket directly onto a telescoping steering column.</p> <p>Ensure the steering column telescope lock/unlock knob is working correctly. If the steering column cannot be set in a fixed position, the column could telescope freely inward, causing the bracket to strike the instrument panel.</p>	

<p>Steering wheel is loose on steering shaft</p>	<p>A steering wheel with vertical “play” (see white arrow) does not provide good contact with the EZ–Steer 500 system drive wheel.</p> <p>The drive wheel could slip on the steering wheel outer ring, causing a loss in steering accuracy.</p> <p>Tighten the steering wheel.</p>	
<p>Front steering is out of alignment</p>	<p>If one or both of the front wheels are out of alignment, the steering will pull to one side and the machine will constantly steer to the left or right and will have problems following a straight or curved line.</p> <p>Fix the machine's front wheel alignment before installing and calibrating the EZ–Steer system.</p>	
<p>Steering wheel is dirty</p>	<p>Grease, oil, or protectants such as Armor All may cause the foam drive wheel to slip on the steering wheel.</p> <p>Use denatured alcohol to clean the steering wheel.</p>	

Electrical Problems

PROBLEM	CAUSE/SOLUTION	PHOTO
<p>No power from accessory socket</p>	<p>Plug in the EZ–Steer power cable and flip the switch on the male power adaptor. If the accessory socket has power, the green light on the switch is lit.</p>	

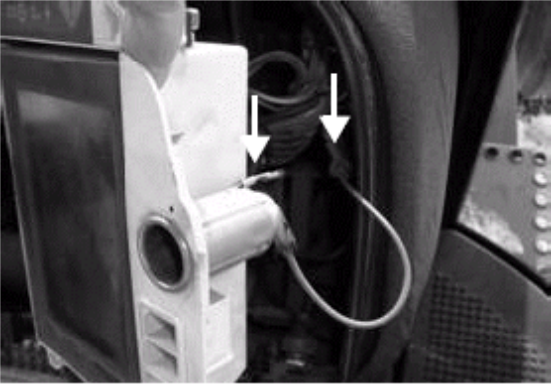
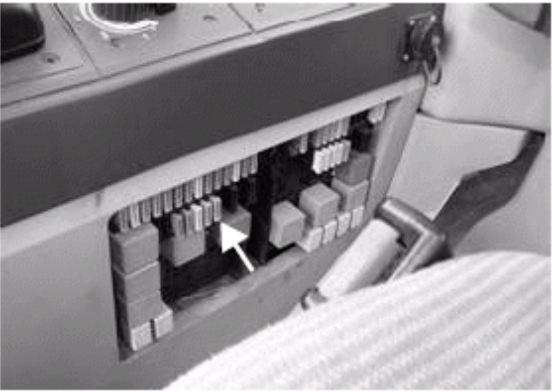
	<p>If the accessory socket does not have power, check:</p> <ul style="list-style-type: none"> * that the accessory socket is connected * if an in-line fuse has been added and/or if the fuse is blown 	
<p>Fuse is too small for power accessory socket</p>	<p>The fuse must be 10 amp or larger. Replace with a larger fuse if necessary.</p>	

Hydraulic Fluid

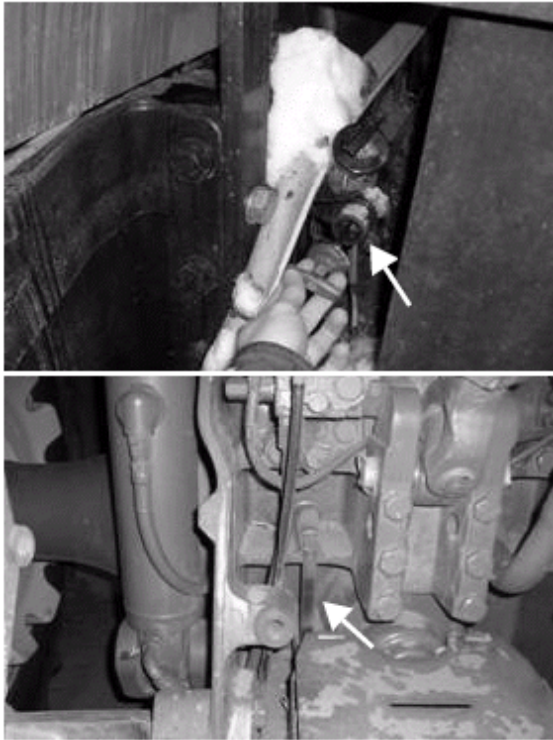
PROBLEM	CAUSE/SOLUTION	PHOTO
<p>Low hydraulic fluid level</p>	<p>A low level of hydraulic fluid, or old fluid, can cause the steering wheel to turn the front wheels very erratically, or not at all.</p> <p>Use a dipstick or sight gauge to check the fluid level.</p> <p>Top up or replace the hydraulic fluid as necessary.</p>	

<p>Cold hydraulic fluid</p>	<p>If the hydraulic oil temperature is lower than 40 °C (100 °F), the machine's steering may be stiff, causing the EZ–Steer 500 system to automatically disengage or respond slowly to steering wheel movements. Before using the system, wait for the hydraulic oil to reach the recommended operating temperature.</p> <p>High clearance sprayers are prone to having slow steering response until the hydraulic fluid temperature is 66 °C–82 °C (150 °F–180 °F).</p>	 The icon consists of two black symbols. On the left is a large, thick-lined outline of a teardrop shape, representing a drop of hydraulic fluid. To its right is a vertical thermometer with a bulb at the bottom and a narrow tube extending upwards, representing a temperature measurement.
-----------------------------	--	---

Installation

Installation Process

1. Install the EZ–Steer motor using the platform kit.
2. Install the controller.
3. Mount the GPS antenna.
4. Install optional switches.
5. Connect the components together.

Caution – Do not change the system cabling while it is running. Do not disconnect or connect any cables or connect the EZ–Steer system while the lightbar is running. To connect or disconnect cables, first turn off the system.

STEP 1: Installing the motor with the platform

To install the EZ–Steer 500 platform kit and motor on the steering column of a vehicle, follow the instructions provided with the platform kit.

Also, check for vehicle–specific installation notes at www.EZ–Steer.com.

CAUTION – Always hold the steering wheel while you adjust the column tilt. Otherwise, the weight of the motor may cause the steering wheel to drop suddenly and cause damage to the steering column or dashboard.

Check that the EZ–Steer 500 system motor is mounted at an appropriate distance from the steering wheel. The foam wheel should be 3.2 cm (1¼ inches) from the steering wheel when the motor is locked away.

Lock the motor drive wheel away from the steering wheel when the system is not in use. This prevents the foam wheel from developing a flat spot.

Note – If the foam wheel develops a flat spot, you can still use the motor drive wheel. The flat spot does not affect the drive wheel, and will eventually disappear.

STEP 2: Installing the controller

Install the controller in a way that prevents dust and moisture from entering it.

Controller Mounting Locations

Install the controller in the vehicle cab, parallel to the vehicle’s center line and in one of the following locations:

FLOOR MOUNT	VERTICAL MOUNT
Parallel to the center line of the vehicle, white sticker facing upwards	Perpendicular to the floor and parallel to the rear axle, with the

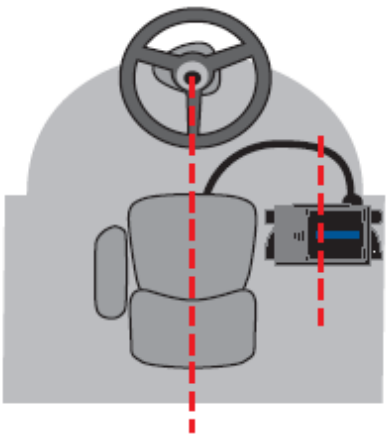
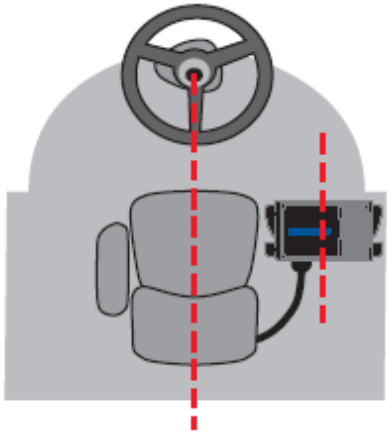
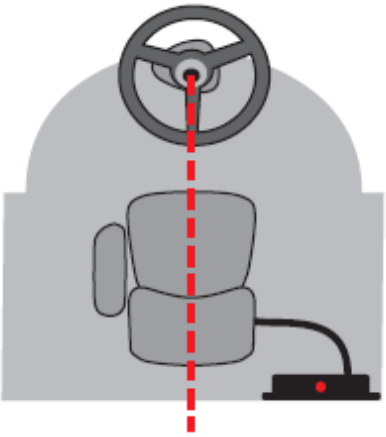
Connectors facing forward (preferred)	Connectors facing backward	connectors pointing down toward the floor, white sticker facing towards the front of the vehicle
		
Take extra care not to stand on, kick, or otherwise damage the controller.		

CAUTION – Do not attach the controller to the vehicle rear window because vibration in this location can cause the controller to output false terrain compensation readings that could affect performance and cause the vehicle to swerve offline.

Controller Mounting

If you mount the controller on the floor, look for any cab wiring routed under the floormat before screwing the controller into place.

Use screws that are size #12 or #14, and between ½" and 1" long.

CAUTION – Mount the controller as solidly as possible, using the supplied mounting plate. If objects bump the controller, or if the controller vibrates, false terrain compensation readings are created that could affect performance and cause the vehicle to swerve offline.





CAUTION – The EZ–Steer 500 system is not designed to be mounted on machines with an open operator's station (no enclosed operator's cab). Doing so will void the warranty of the EZ–Steer 500 system components.



STEP 3: Mounting the GPS antenna

For optimal performance, mount the antenna at the front of the cab with a clear view of the sky. Antenna mounting locations for each vehicle type are shown below.

CAUTION – Ensure that you mount the antenna so that it is level. If the antenna is not level, GPS performance may be reduced.

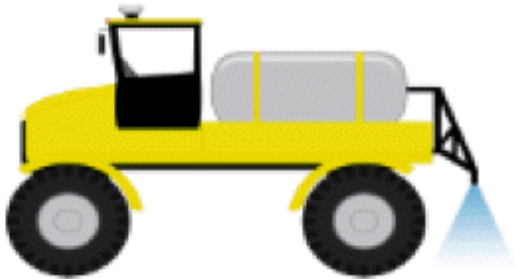
VEHICLE	ANTENNA MOUNTING LOCATION
---------	---------------------------

2WD tractor	
4WD tractor	
Tracked tractor	
Combine	
Sprayer	

Truck	
Floater	
Swather / Windrower	

STEP 4: Connecting optional switches

You can connect one of the following switches to the EZ–Steer 500 system:

- Seat switch to prevent engaging when the operator is not in the seat
- Remote–engage foot pedal

The switches connect to the optional accessory cable kit (P/N 53066–00).

ITEM	DESCRIPTION
1	EZ–Steer 500 controller connector
2	Alarm connector
3	Switch input connector

To purchase the optional accessory cable kit, or for more information, contact your local EZ–Steer 500 system reseller.

Connecting a Seat Switch

As an additional safety feature, you can connect a vehicle seat switch to the EZ–Steer accessory cable:

1. Strip about 2.5 cm (1 inch) of insulation off the switch wire.
2. Thread each switch wire through a cable seal.

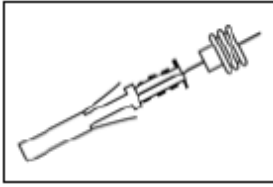

3. Insert the switch wire and end of the cable seal into the female terminal connector.
4. Crimp the female terminal connector with an appropriately sized crimp tool or pliers, and then solder to ensure a good physical and electrical connection. Do not let excess solder run into other parts of the contact.
5. Insert the two female terminal connectors and the rubber seal into the two holes of the 2-way female connector.

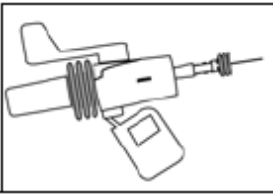

6. Plug the 2-way female connector into the 2-way male connector on the accessory cable.



To enable the seat switch:

1. Select *Configuration / Auto Steer / EZ-Steer Setup / Engage Options / EZ-Steer External Switch*.
2. Select one of the following options:

OPTION	DESCRIPTION
Disabled	The switch is disabled.
Seat Disengage	The operator must be sitting on the seat before assisted steering will engage and the system disengages when the operator leaves the seat.
Seat Engage Only	The operator must be sitting on the seat before assisted steering will engage. Assisted steering does not disengage when the operator leaves the seat.
Remote Engage	The switch engages and disengages the EZ-Steer system.

3. Press  to save the setting.

Connecting a Remote-Engage Foot Pedal

If you use a foot pedal to engage the EZ-Steer 500 system, the foot pedal must be connected to the optional accessory cable.

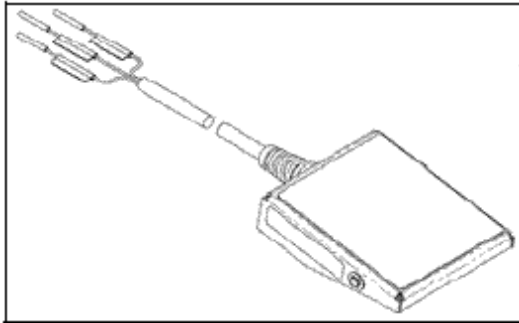

For information on purchasing a foot pedal kit (P/N 60941-00), contact your local EZ-Steer 500 system reseller.

To connect the foot pedal to the accessory cable:

1. Cut the pins off the black and white wires on the foot pedal cable and strip about 2.5 cm (1 inch) of insulation off the switch wires.

Note – The green wire is not used and can be cut off if required.

2. Thread each of the black and white switch wires through a cable seal (supplied with the accessory cable).
3. Insert each of the switch wires and the end of the cable seal into a female terminal connector.

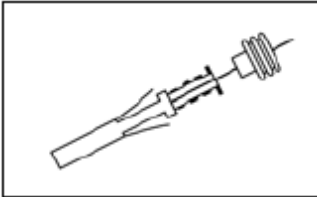

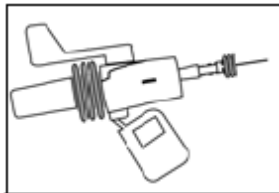

4. Crimp the female terminal connectors with an appropriately sized crimp tool or pliers, and then solder to ensure a good physical and electrical connection. Do not allow excess solder to run into other parts of the contact.
5. Insert the two female terminal connectors and the rubber seal into the two holes of the 2-way female connector as follows:

- ◆ Black wire into terminal B.
- ◆ White wire into terminal A.



6. Plug the 2-way female connector into the 2-way male connector on the accessory cable.



7. Run the cable to a clear location on the floor board. Use doublesided tape or wide velcro strips to secure the pedal. Route the cable under the floor mat.
8. Select *Configuration / Auto Steer / EZ-Steer Setup / Engage Options / EZ-Steer External Switch*.
 - a. Press  until *Remote Engage* is selected.
 - b. Press  to save the setting.

To engage or disengage the EZ–Steer 500 system using the remote engage foot pedal, depress the pedal for 0.5–3 seconds and then release it when you pass the start of the swath. The system engages when the pedal is released. This is done to avoid accidental engaging. To disengage the EZ–Steer 500 system, just turn the steering wheel at the end of the swath, stop, or depress the pedal again.

STEP 5: Connecting the components

Connect the EZ–Guide 500 lightbar and the EZ–Steer 500 system components as shown here:

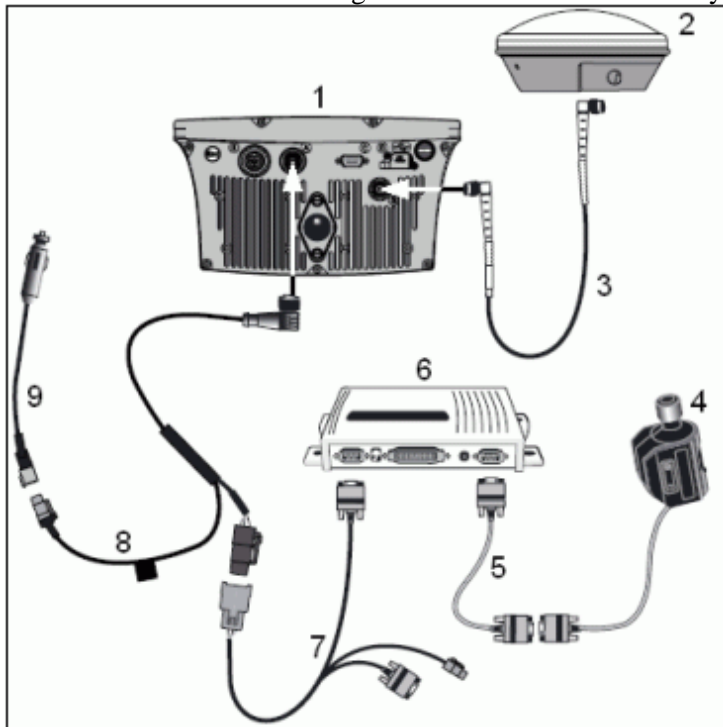

ITEM	DESCRIPTION
1	Lightbar
2	Antenna
3	Antenna cable (P/N 50449)
4	EZ–Steer motor
5	Motor cable
6	Controller
7	EZ–Guide–to–EZ–Steer cable (P/N 62974)
8	Power cable (P/N 62817)
9	Power connection cable (P/N 62818)

Calibration

Introduction

The EZ–Steer Calibration wizard guides you through the T2 roll calibration and EZ–Steer 500 calibration process to ensure you get the best performance from your system.

EZ–Steer Calibration Wizard Process

1. Start the EZ–Steer Calibration wizard
2. Enter the vehicle settings
3. Perform the T2 roll calibration
4. Calibrate the EZ–Steer settings:
 - a. Calibrate the Angle per Turn
 - b. Calibrate Aggressiveness
 - c. Calibrate Freeplay Offset
5. Confirm the calibration settings

Note – It may be necessary to run the EZ–Steer Calibration wizard more than once to achieve optimal results. If you run the wizard again, ensure that you do not reset the Angle per Turn, Aggressiveness, and Freeplay Offset to the vehicle default.

Note – Do not turn off the system while the EZ–Steer Calibration wizard is running. If power is disrupted during the calibration, change the GPS source and then change it back again as an interrupted calibration sequence can cause it to be incorrectly set. Then repeat the calibration process because the settings may not be correct.

Before Starting the EZ–Steer Calibration Wizard

1. Complete the vehicle inspection and installation. See the Pre–installation Vehicle Inspection and Installation chapters.
2. Map a straight AB Line and line the vehicle up 1 m (3 ft) from one of the guidance lines. Ensure that the vehicle is parallel to the line. For information on mapping an AB Line, refer to the EZ–Guide 500 system documentation.

Note – If an AB Line is not defined when the EZ–Steer Calibration wizard is started, you are prompted to map an AB Line.

Before calibrating the vehicle, note the following:

- Ensure that the hydraulic oil is at normal operating temperature before calibrating the system.
- Ensure the tire pressures are correct.
- Choose a field with the smoothest surface and perform calibration at the normal operating speed for the vehicle.

Note – Perform initial calibration without an implement or with the booms folded in on a high clearance sprayer.

After initial calibration is completed, the settings can be fine-tuned with the implement or booms folded out.

STEP 1: Starting the EZ-Steer Calibration Wizard

If the system has not been calibrated, the EZ-Steer Calibration wizard automatically appears when the lightbar is turned on.

To manually start the EZ-Steer Calibration wizard at other times, select *Configuration / Auto Steer / EZ-Steer Setup / EZ-Steer Calibration Wizard*.

The *EZ-Steer Calibration Wizard* screen appears:

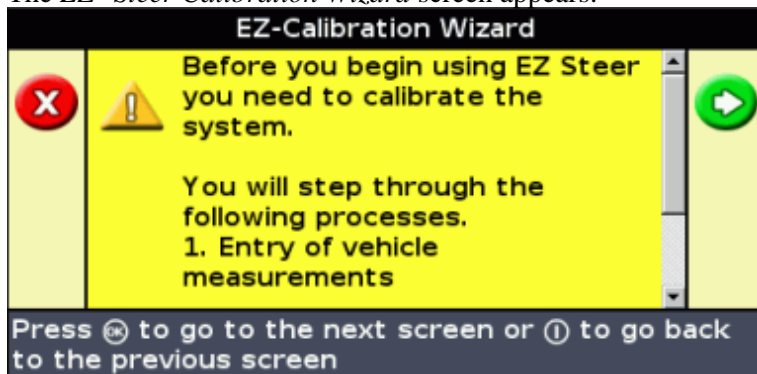

STEP 2: Entering the Vehicle Settings

1. Select the vehicle type.

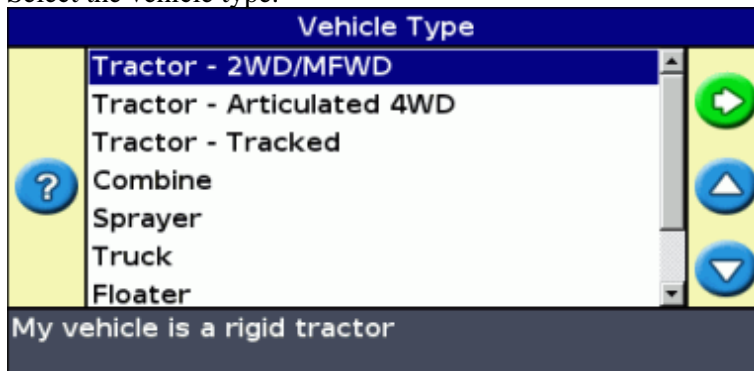

Note – The onscreen graphics will reflect the vehicle type that you select.

2. Enter the vehicle wheelbase.

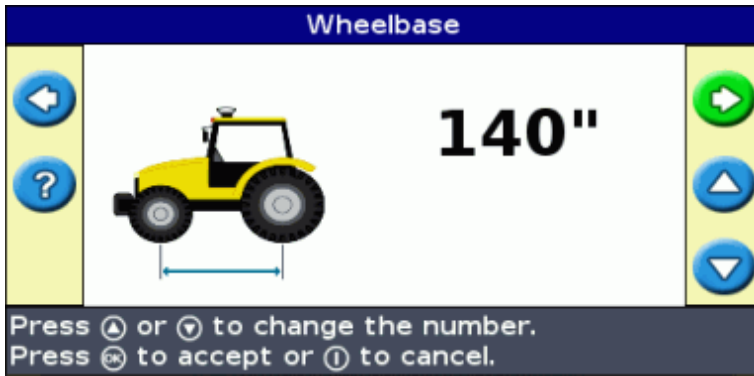

Measure the horizontal distance that is appropriate for the selected vehicle type:

- ◆ 2WD/MFWD / 4WD tractor / Combine / Sprayer / Truck / Floater / Swather/Windrower – from front axle to rear axle
- ◆ Tracked tractor – half the distance from front axle to rear axle with the steering straight

Tip – If these settings do not provide optimal performance for a 4WD tractor, try entering half the wheelbase.

Tip – If these settings do not provide optimal performance for a tracked tractor, try entering the full track length.

3. Enter the antenna height.

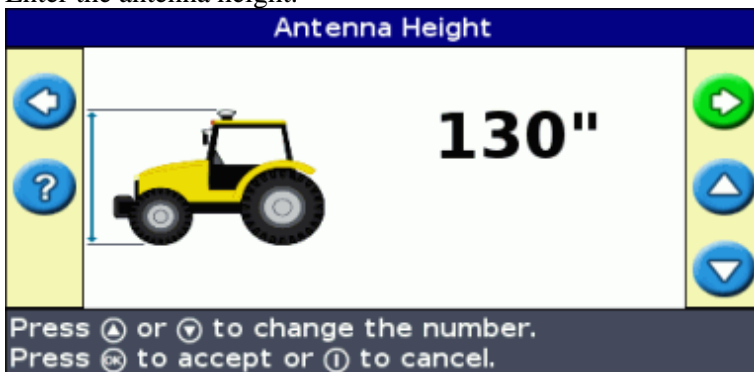

Measure the distance from the ground to the top of the GPS antenna.



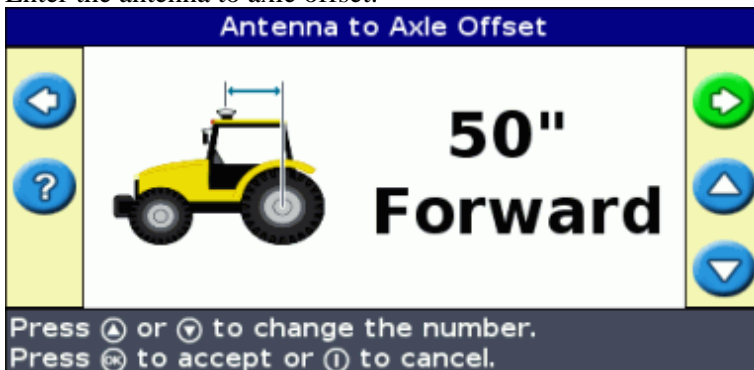

4. Enter the antenna to axle offset.



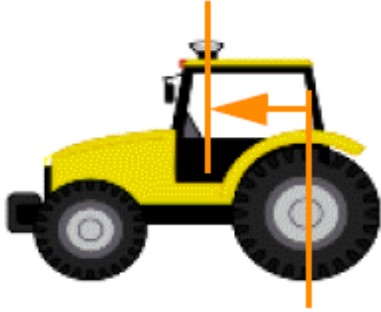

Measure the distance from the reference point to where the antenna is mounted.

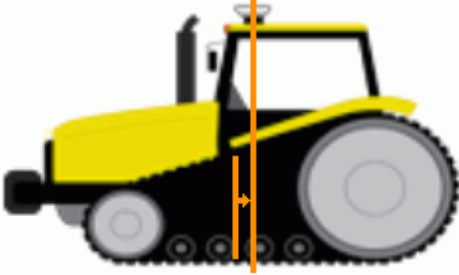
CAUTION – Ensure that the antenna offset measurement is accurate to within 7.6 cm (3 inches). An incorrect offset can cause the vehicle to swerve offline or oscillate back and forward and may cause damage to the vehicle or other property.

The following table shows the antenna offset reference point for each vehicle type:

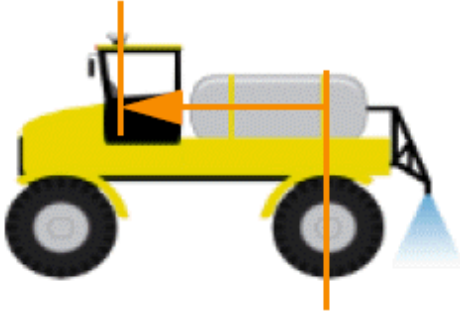
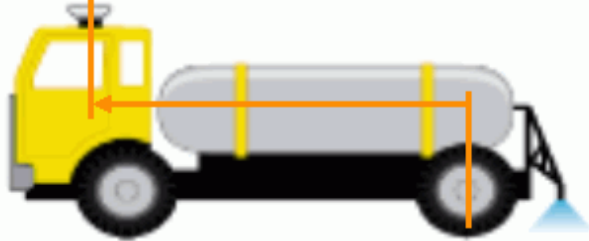
VEHICLE TYPE	EXAMPLE
2WD tractor	
4WD (articulated tractor)	
Tracked tractor	
Combine	

Sprayer	
Truck	
Floater	
Swather / Windrower	

Note – Take particular care to ensure that the correct direction of offset from the antenna mount reference mount is selected.

STEP 3: Completing T2 Roll Calibration

Roll compensation uses the T2 terrain compensation technology in the EZ–Steer controller. Follow the on–screen instructions to complete the T2 roll calibration.

1. Select the direction that the controller connectors point.

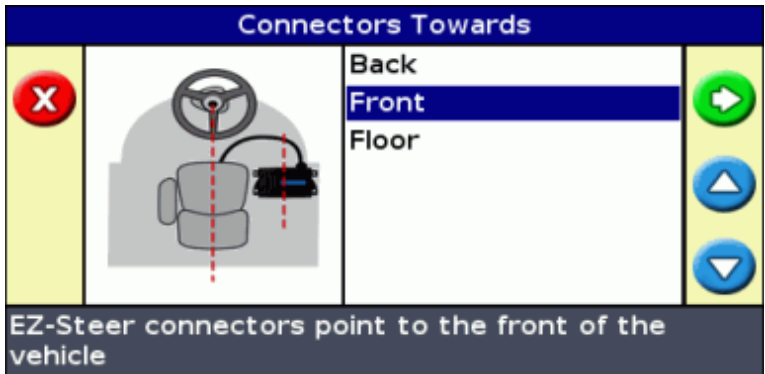

2. Park the vehicle and mark the inside position of both sets of wheels.

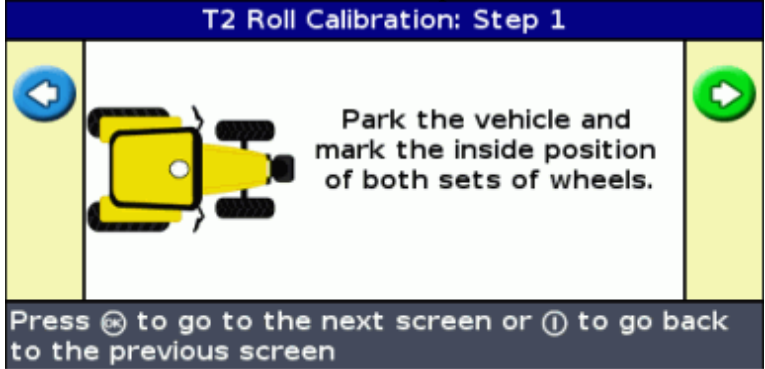

3. Press **[OK]** to take the first calibration reading. This takes approximately 20 seconds. Do not move the vehicle while the offset is being read.
4. Turn the vehicle around and park it, ensuring that the wheels are directly over the positions marked previously.

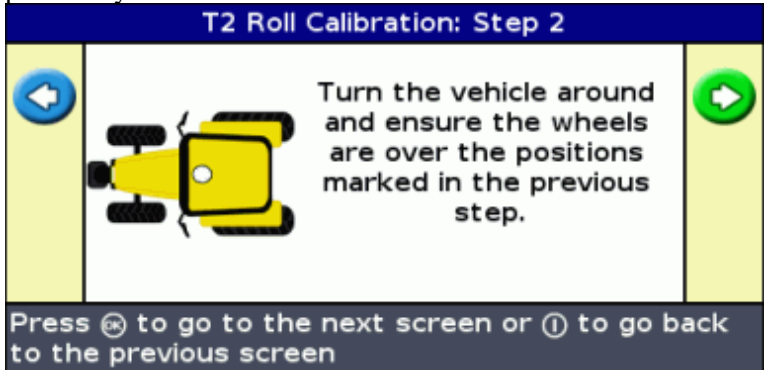

5. Press **[OK]** to take the second calibration reading. This takes approximately 20 seconds. Do not move the vehicle while the offset is being read.
6. Review the roll calibration settings.

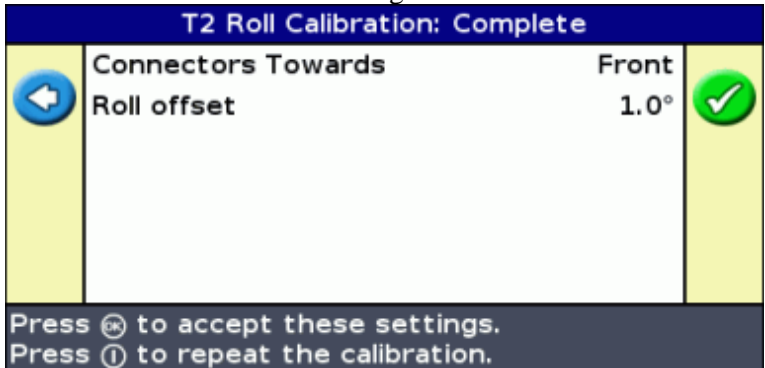

Note – The Roll offset should have a value between 0 degrees and 4 degrees, and a left or right offset indicated by a L or R symbol.

Note – You can also perform the T2 calibration by creating an AB Line, parking the vehicle over the line so the 3 green LEDs are showing, and then marking the halfway point between the axles.

If you have completed a calibration before, the *Reset Parameters* screen appears.

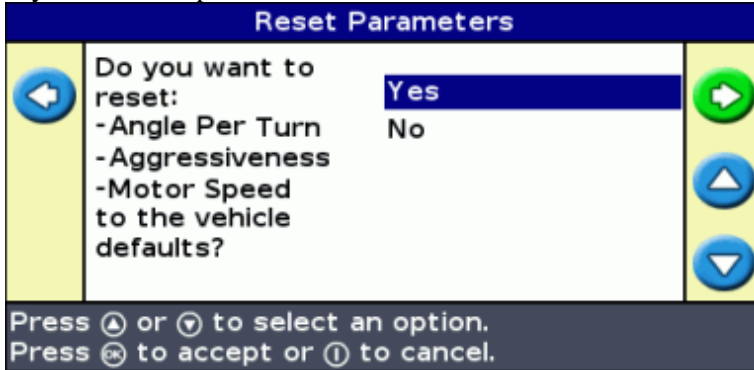

The screen asks if you want to reset the vehicle settings:

- ◆ If you are replacing the previous calibration, select *Yes* .
- ◆ If you are fine-tuning the calibration settings, select *No* to retain your current settings.

STEP 4: Calibrating EZ–Steer 500 System Settings



Minimizing offline distances

The calibration of all parameters involve engaging the EZ–Steer 500 system on a guidance line, then changing the parameter until you have minimized the offline distances.

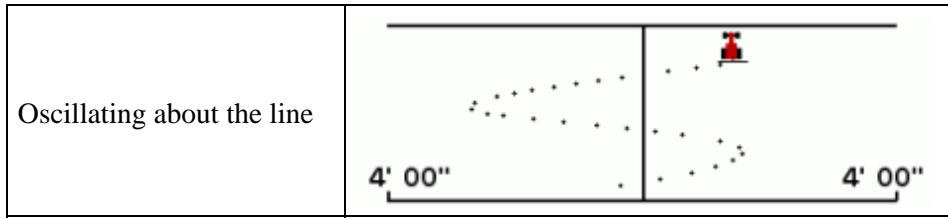
RESULT	EXAMPLE
Ideal	
Slow to get online	



Procedure to minimize the offline distance

1. Line the vehicle up on any swath.
2. Drive the vehicle at normal operating speed.
3. Press the engage button to engage the system.
4. While the system is engaged, press  or  to adjust the value, until you get the best performance.
5. Press  . The system disengages and the next screen appears.

Calibrating Angle per Turn

The *Angle per Turn* value represents the angle that the wheels turn through during one full rotation of the steering wheel.

A low *Angle per Turn* setting causes the system to turn the steering wheel more, and a high *Angle per Turn* setting causes the system to turn the steering wheel less.

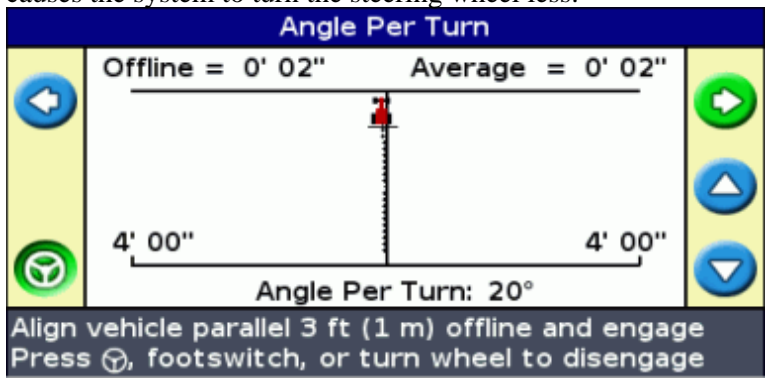

- If the setting is too low, the system will turn the steering wheel too much and the vehicle will perform s-turns.
- If the setting is too high, the system will turn the steering wheel too little and the vehicle will not hold the line.

Calibrating Online Aggressiveness

The *Online Aggressiveness* setting controls how aggressively the EZ-Steer 500 system holds the guidance line once it is online.

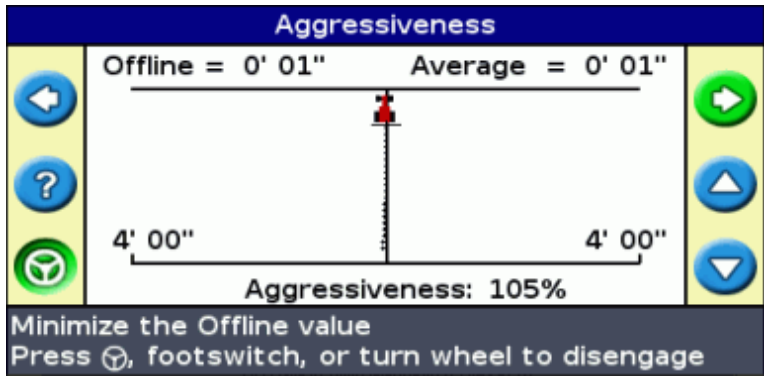

Adjust the *Online Aggressiveness* value until maximum online accuracy is achieved, but without oscillations.

TO ...	DO THE FOLLOWING ...
Make more aggressive turns to stay online	Increase the Aggressiveness value
Make less aggressive turns to avoid oscillations	Decrease the Aggressiveness value

Calibrating Freeplay Offset

The *Freeplay Offset* setting adjusts the steering if the vehicle has a greater freeplay offset in one direction than the other.

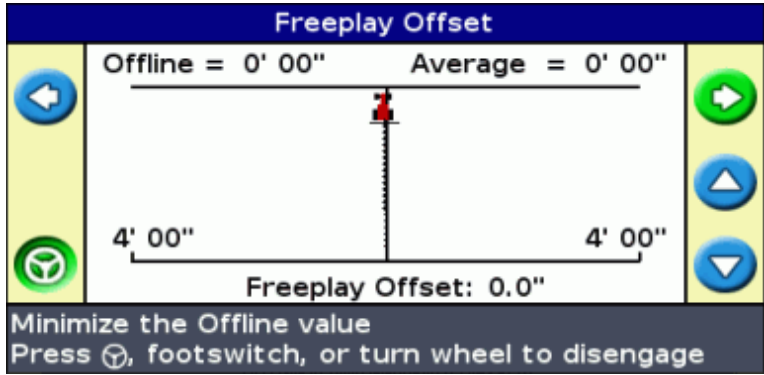

Adjust the freeplay offset if the vehicle drives consistently to one side of the line:

IF THE VEHICLE IS ...	DO THE FOLLOWING ...
Offline to the left	Increase the freeplay offset to the right
Offline to the right	Increase the freeplay offset to the left

Calibrating Motor Speed

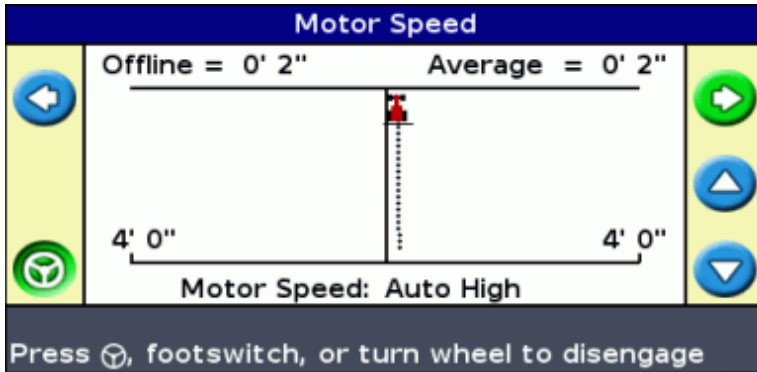

If you are calibrating a 4WD articulated vehicle, you will be prompted to set the *Motor Speed* setting. The *Motor Speed* setting helps to:

- increase steering response
- decrease noise
- decrease vibration



At higher speeds, use a high motor speed. At lower speeds, use a low motor speed to reduce noise and steering column vibrations.



Adjust the motor speed to minimize offline distances.

- Press  or  to cycle through the different settings.

STEP 5: Confirming the Calibration Parameters

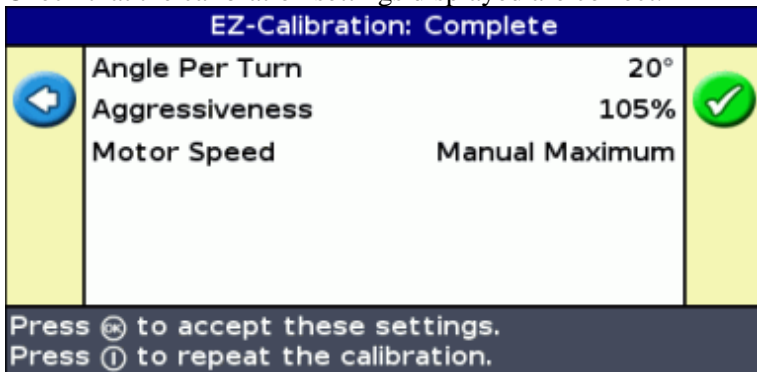
1. Check that the calibration settings displayed are correct.



2. To complete the calibration, press .
3. To repeat the calibration to fine-tune settings, press .

Using The EZ–Steer System

Introduction

This chapter contains information on how to operate the system.

For information on using the EZ–Guide 500 lightbar, refer to the *EZ–Guide 500 Lightbar Guidance System Quick Reference Card* or *Getting Started Guide*.

Screen Items

The following graphic shows the screen items relating to the EZ–Steer 500 assisted steering system:

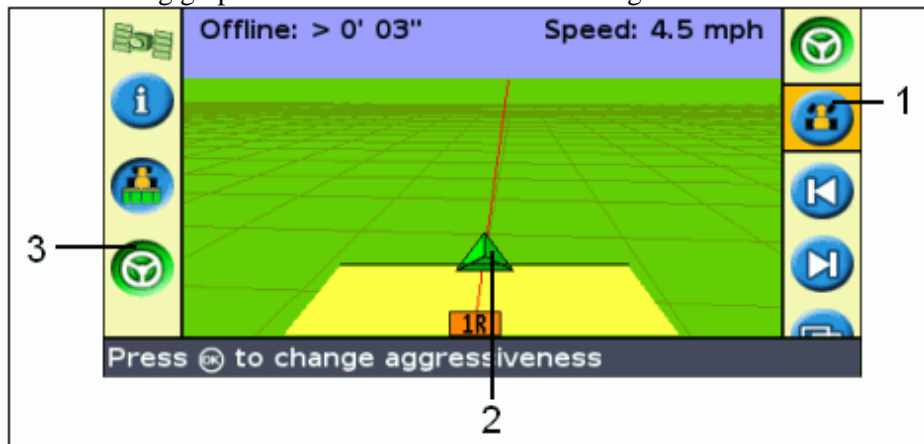

ITEM	DESCRIPTION
1	Aggressiveness icon
2	Vehicle icon
3	Engage button

Engage Status Indication

ENGAGE STATUS	ENGAGE BUTTON COLOR	VEHICLE ICON COLOR	LED INDICATION
Ready to engage			1 solid LED at each end
Engaged			2 solid LEDs at each end

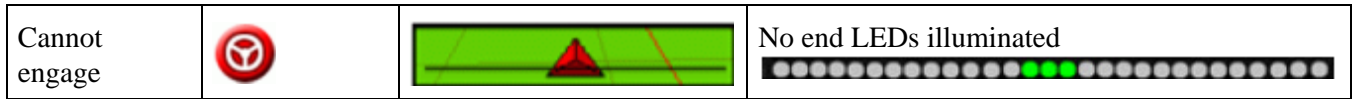

Engaging

Before you can engage the EZ–Steer 500 system, you must define an AB Line, and drive the vehicle close to the guidance swath.

Before engaging, point the nose of the vehicle towards the guidance line and drive at operational speed. When the system indicates it is ready to engage, do one of the following:

- Press the engage button  on the main map screen or on the optional remote control.
- Press the optional remote engage foot pedal.

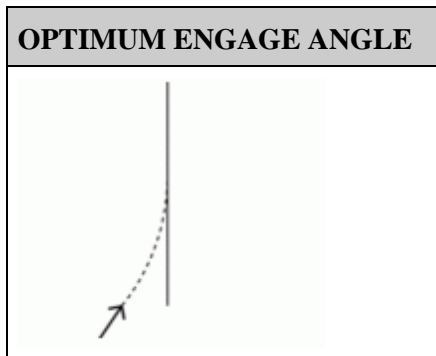

Disengaging

EZ–Steer 500 system automatically disengages when:

- The vehicle is outside the engage limits configured in the *Engage Options* screen
- The system is paused
- GPS positions are lost
- The GPS accuracy is below the *Minimum Fix Quality* setting. If *Configuration / System / GPS / GPS Limits / Minimum Fix Quality* is set to a high accuracy correction, the system disengages if it receives low accuracy positions (for example, no corrections).

To manually disengage the system, do one of the following:

- Press the engage button  on the main map screen or on the optional remote control.
- Turn the steering wheel to override the electric motor.
- Press the optional remote engage foot pedal.

When the system is not in use, use the motor lock pin to tilt the motor away from the steering wheel.

Curve Autosteering Accuracy

Headlands

It is possible to engage the EZ–Steer 500 system on headlands which have sharp corners at the edge of the field. However, the EZ–Steer 500 system may be unable to drive around these sharp bends. Use one of the following methods to compensate:

- Manually steer the vehicle around the corner. Once you have rounded the corner, re–engage the EZ–Steer 500 system.
- Select *Configuration / Auto Steer / EZ–Steer Setup / Engage Options* and increase the *Disengage Offline* distance.

Engage Options (Advanced Mode Only)

The *Engage Options* screen has options that control the engage (and disengage) behaviour of the system. (Select *Configuration / Auto Steer / EZ–Steer Setup / Engage Options*).

OPTION	DESCRIPTION
Minimum Speed	The minimum speed at which the system can engage. If the system is engaged and the speed drops below this limit, the system disengages.
Maximum Speed	The maximum speed at which the system can engage. If the system is engaged and the speed increases above this limit, the system disengages.
Maximum Angle	The maximum angle at which the system can engage. If the vehicle approaches the swath at an angle greater than this limit, it cannot be engaged.
Engage Offline	The maximum distance from the swath at which the system can engage. If the vehicle approaches the swath at a distance greater than this limit, it cannot be engaged.
Disengage Offline	The maximum distance from the swath at which the system can remain engaged. If the vehicle drives offline greater than this limit, the system disengages.
Engage on AB	Used to configure whether the system can be engaged on the master AB line.
Override Sensitivity	The amount that the steering wheel must be turned manually before the system disengages.
EZ–Steer External Switch	Used to configure the behaviour of a seat/foot switch.

Vehicle–Specific Performance Hints

2WD tractor

- You can install the EZ–Steer 500 system on tractors that have SuperSteer (for example, New Holland TG). If the tractor has a SuperSteer front axle, for best performance:

- Reduce the *Online Aggressiveness* value.
- Line up close to the swath and make certain the front wheels are straight before engaging the EZ–Steer 500 system.
- To get smoother performance when the vehicle is pulling an implement over tilled ground, enable the *Diff–Lock*. This prevents the machine from pulling sharply to the left or right.

Note – Turn off Diff–Lock if you are calibrating on a hard surface.

4WD tractor

- The EZ–Steer 500 system can be installed on Case IH STX tractors with Accusteer. For optimal performance, disable Accusteer via the switch in the cab if possible.

Sprayer

- It is common for these vehicles to have slow steering. To compensate for this, use high aggressiveness.
- If you experience large, slow oscillations, increase the aggressiveness.
- When you configure the system on a sprayer, the *Sprayer steering delay* setting is available on the *Vehicle Setup* screen. Some sprayers have steering that is slow to react after the steering wheel is turned. The system uses the steering delay setting to compensate for this slowness and ensure that steering corrections occur at the correct point. To access the *Vehicle Setup* screen, select *Configuration / Auto Steer / EZ–Steer Setup / Vehicle Setup*.

Swather

- When you configure the system on a swather, the *Swather steering delay* setting is available on the *Vehicle Setup* screen. Some swathers have steering that is slow to react after the steering wheel is turned. The system uses the steering delay setting to compensate for this slowness and ensure that steering corrections occur at the correct point. To access the *Vehicle Setup* screen, select *Configuration / Auto Steer / EZ–Steer Setup / Vehicle Setup*.

To improve the performance of your swather, only adjust the *Swather steering delay* setting by a small amount (0.1 seconds) at a time. Test the result between each adjustment.

Troubleshooting

Introduction

This chapter contains remedies to possible problems. The troubleshooting information is separated into general, general GPS and system performance.

General

PROBLEM	POSSIBLE CAUSE	SOLUTION
The EZ–Steer 500 system is hard to disengage when you manually turn the steering wheel.	The <i>Override Sensitivity</i> setting is too low.	Select <i>Configuration / Auto Steer / EZ–Steer Setup / Engage Options</i> and then increase the <i>Override Sensitivity</i> setting. Increase the setting in 5% increments. Disengage by turning the steering wheel after each change to test its effect.
The EZ–Steer 500 system disengages on large bumps.	The <i>Override Sensitivity</i> setting is too high.	Select <i>Configuration / Auto Steer / EZ–Steer Setup / Engage Options</i> and then decrease the <i>Override Sensitivity</i> . Decrease the setting in 5% increments. Disengage after each change to test its effect.
It is difficult to engage the EZ–Steer 500 system.	The <i>Maximum Angle</i> setting is too narrow, making it difficult to line up the vehicle within the engage angle.	Select <i>Configuration / Auto Steer / EZ–Steer Setup / Engage Options</i> and then increase the <i>Maximum Angle</i> setting.
	The <i>Engage Offline</i> limit is too low which means that the vehicle has to be very close to the line before engaging.	Select <i>Configuration / Auto Steer / EZ–Steer Setup / Engage Options</i> and then increase the <i>Engage Offline</i> limit.
The remote engage foot pedal does not work.	Holding the switch shorter than 0.5 seconds will not engage the system.	Hold the switch down for at least 0.5 seconds. Release the switch between 0.5 and 3.0 seconds. The vehicle will engage when the switch is released.
The foam motor drive wheel vibrates.	The motor wheel has a flat spot because it was not locked away from the steering wheel when the vehicle was not in use.	When the system is not in use, hinge the EZ–Steer 500 motor until it locks in the "away" position. The flat spot usually disappears after an hour of operation. If the float spot does not go away, replace the foam wheel.
The foam wheel slips on the steering wheel.	Grease, oil, or protectants such as Armor All may cause the foam drive wheel to slip on the steering wheel.	Clean the steering wheel with denatured alcohol to remove grease, oils, and protectants. Loosen the thumb screws and move the motor closer to the steering wheel. This increases the

	There is not enough pressure between the drive wheel and the steering wheel.	pressure and stops slippage.
The EZ–Steer 500 motor struggles to turn the steering wheel of the vehicle.	An excessively worn steering column is binding in its housing inside the steering shaft when the EZ–Steer 500 motor presses against it.	Repair or replace the steering shaft.
The EZ–Steer 500 motor repeatedly disengages immediately after you engage the system.	The steering hydraulic temperature is low, and the steering of the vehicle is very stiff and hard to turn.	Decrease the steering override by 5% increments to 20% or less. Engage the EZ–Steer 500 system to see if the problem stops.

General GPS

PROBLEM	POSSIBLE CAUSE	SOLUTION
On–the–ground pass to pass errors are greater than 0.3 m (12 inches).	The GPS position is drifting by more than 0.3 m (12 inches) over two passes.	Change the OnPath advanced filter technology setting.
	<i>Note – The receiver specification shows accuracy should be 15 cm–30 cm (6 inches–12 inches) 95% of the time in the American Midwest. If you are not using GPS corrections, the accuracy specification is 15–46 cm (6 inches–18 inches) in open fields with a decay time setting of greater than 30 minutes.</i>	
	The antenna is not level, which may cause GPS signal errors in some directions.	Ensure that the antenna is mounted within 5 degrees of horizontal.
The GPS position jumps up to several feet soon after startup.	For optimal accuracy with WAAS corrections, the WAAS ionosphere model must be downloaded to the receiver, which can take up to 10 minutes. When the download is complete, the GPS position is updated, which can lead to a position jump of up to several feet.	Wait for 10 minutes after getting your first DGPS position before you start to use guidance or autosteering.
Intermittent GPS or WAAS signals – the receiver intermittently loses WAAS correction or GPS positions or only ever tracks seven satellites or less.	The GPS antenna is being blocked by part of the vehicle.	Mount the antenna at least 0.9 m (3 feet) away from any obstruction or source of potential interference. Remove any obstacle that may be blocking GPS signals. <i>Note – If you move the antenna, recalibrate the EZ–Steer 500 system.</i>

<p>When I use electrical devices in the cab, the EZ–Guide 500 system loses satellites.</p>	<p>Some electrical devices interfere with GPS signals. If a device emits interference, GPS signals may be jammed. Certain types of two–way radio, DVD players, and some transmitting devices can cause this problem.</p>	<p>If you permanently lose all satellites or only ever get zero or one satellites on a regular basis, switch off all electrical devices in the cab one by one until you isolate the device that causes the issue. If this does not work, move the antenna to the nose of the vehicle to avoid interference.</p> <p><i>Note – If you move the antenna, recalibrate the EZ–Steer 500 system.</i></p>
<p>The vehicle moves offline when I drive past trees.</p>	<p>Trees obstruct GPS signals. If a tree is partially blocking a satellite, the GPS position may shift.</p>	<p>Autonomous GPS Increase the <i>Minimum SNR</i> setting (select <i>Configuration / System / GPS / GPS Limits</i>).</p> <p>Tip: Raise the <i>Minimum SNR</i> value to 42. If this does not fix the issue, set the <i>Minimum SNR</i> value to 45.</p> <p><i>Note – Altering this setting may affect the overall number of satellites you are able to track. If you do not get a GPS position, drop the setting back to its default value of 40.</i></p> <p>OmniSTAR XP/HP Decrease the <i>Minimum SNR</i> setting (select <i>Configuration / System / GPS / GPS Limits</i>).</p> <p>Tip: Lower the <i>Minimum SNR</i> value to 35.</p>

System Performance

Oscillations

PROBLEM	POSSIBLE CAUSE	SOLUTION
---------	----------------	----------

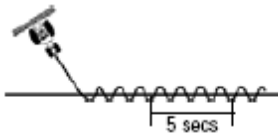
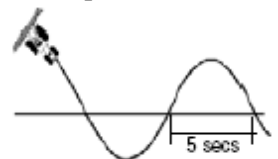
<p>The vehicle is oscillating quickly (more than 5 seconds per oscillation)</p> 	The antenna is behind the rear axle.	Place the antenna in front of the rear axle. Check the axle/antenna offset.
	The <i>Angle/Turn</i> setting is too low.	Repeat the EZ–Steer Calibration wizard.
	The <i>Aggressiveness</i> setting is too high.	Repeat the EZ–Steer Calibration wizard.
<p>The vehicle is oscillating slowly (>5 sec per oscillation)</p> 	The vehicle is oscillating from one side of the line to the other in board sweeps because the <i>Angle/Turn</i> setting is too high.	Repeat the EZ–Steer Calibration wizard.
	The <i>Aggressiveness</i> setting is too low.	Repeat the EZ–Steer Calibration wizard.
	(4WD vehicles) The <i>Motor Speed</i> setting is too low.	Adjust the <i>Motor Speed</i> setting.

Offline

PROBLEM	POSSIBLE CAUSE	SOLUTION
The lightbar shows online but when I look at the marks from my last pass, I see gaps.	GPS error.	Refer to General GPS section.
	T2 terrain compensation is not calibrated correctly.	Repeat the EZ–Steer Calibration wizard.
The vehicle is slow to get online	The <i>Angle per Turn</i> value is too high.	Repeat the EZ–Steer Calibration wizard.
	The <i>Aggressiveness</i> setting is too low.	Repeat the EZ–Steer Calibration wizard.
	(4WD vehicles) The motor speed is too low.	Set the motor speed.
	The T2 terrain compensation is not calibrated correctly.	Repeat the EZ–Steer Calibration wizard.
The EZ–Steer 500 system overshoots the line and disengages.	The vehicle is approaching the line at too steep an angle.	Move the vehicle closer to the line with a shallower angle before engaging.
	The engage limits are too narrow to allow the vehicle to maneuver onto the line.	Increase the <i>Maximum Angle</i> and <i>Disengage Offline</i> settings from <i>Configuration / Auto Steer / EZ–Steer Setup / Engage Options</i> .
	The <i>Aggressiveness</i> setting is too low.	Increase the <i>Aggressiveness</i> setting in increments of 10% up to a limit of 130%.

	<p>The vehicle has greater freeplay in one direction than the other.</p>	<p>Configure the <i>Freeplay Offset</i> setting:</p> <ol style="list-style-type: none"> 1. Select <i>Configuration / Auto Steer / EZ–Steer Setup / Vehicle Setup</i>. 2. When the vehicle is offline: <ul style="list-style-type: none"> – to the right, increase the <i>Freeplay Left</i> field by 0.30 cm (0.1") and decrease the <i>Freeplay Right</i> field by 0.30 cm (0.1"). – to the left, increase the <i>Freeplay Right</i> field by 0.30 cm (0.1") and decrease the <i>Freeplay Left</i> field by 0.30 cm (0.1"). 3. Test the new setting. Adjust the <i>Freeplay Left</i> and <i>Freeplay Right</i> values by a further 0.30 cm (0.1") if necessary. Repeat the process until the vehicle makes only small deviations (± 5.1 cm–15.2 cm (± 2"–6")) either side of the line.
--	--	--

Other

PROBLEM	POSSIBLE CAUSE	SOLUTION
<p>The vehicle steers offline immediately after engaging.</p>	<p>The controller orientation is incorrect.</p>	<p>Check that the controller is correctly installed and configured.</p>
<p>The controller LED is flashing on and off evenly.</p>	<p>This is normal operation.</p>	<p>Do nothing.</p>
<p>The controller LED is flashing with the LED off longer than it is on.</p>	<p>The CAN communication has been lost.</p>	<ol style="list-style-type: none"> 1. Check that the cable connection is secure. 2. Check that the cable is not damaged.
<p>The controller LED is flashing very fast.</p>	<p>There is a controller fault.</p>	<p>Check all equipment and cables for damage. If there is no damage:</p> <ol style="list-style-type: none"> 1. Download the error log to a USB Flash Drive 2. Send the error log to your local reseller.

Messages And Faults



EZ–Steer 500 System Disengaged Warning

Messages appear when the system disengages.



The following table lists all of the disengage messages that may appear.

MESSAGE	EXPLANATION
DISENGAGED! Too fast	EZ–Steer 500 system disengaged because the vehicle is traveling above the maximum speed.
DISENGAGED! Too slow	EZ–Steer 500 system disengaged because the vehicle is traveling below the minimum speed.
DISENGAGED! Too far offline	EZ–Steer 500 system disengaged because the vehicle has gone offline beyond the Disengage Offline value.
DISENGAGED! Manual override	You manually disengaged the EZ–Steer 500 system by turning the steering wheel.
DISENGAGED! Manual disengage	You manually disengaged the EZ–Steer 500 system by pressing the engage/disengage button  .
DISENGAGED! No GPS	EZ–Steer 500 system disengaged because the GPS positions have been lost.
DISENGAGED! No GPS Corrections	EZ–Steer 500 system disengaged because you have no corrections or old corrections.
DISENGAGED! High DOP	EZ–Steer 500 system disengaged because you have high DOP.
DISENGAGED! Control fault	EZ–Steer 500 system disengaged because of a control fault.

Communication Error	There is a poor cable connection or a damaged cable.
EZ-Steer Warning Operator timeout alert	EZ-Steer 500 system has been engaged longer than the operator timeout limit. Press  to continue. If you press  within 30 seconds of the message appearing, the system does not disengage.

T2 Technology System Warning Messages

MESSAGE	CAUSE	SOLUTION
T2 gyros not found	There is a hardware fault in the steering control module (SCM) or bad power supply.	Turn the EZ-Steer 500 system off and then on again.
A fault has occurred with EZ-Steer T2		If the problem persists, see Fault Code 15 in the EZ-Steer system fault codes table below.
T2 gyros have stopped responding		
T2 bias estimate error		

EZ-Steer System Fault Codes

When a fault occurs, a full screen message is displayed.

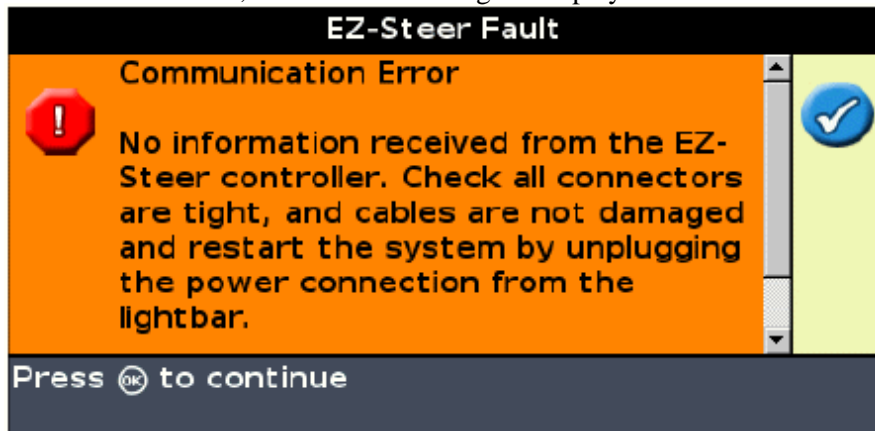

The following table lists all of the faults and their possible causes and solutions.

PROBLEM	POSSIBLE CAUSE	SOLUTION
Fault Code 01: Reduce Override Sensitivity to prevent unintended overrides	There have been a large number of manual overrides on one swath.	Decrease the <i>Override Sensitivity</i> value from <i>Configuration / Auto Steer / EZ-Steer Setup / Engage Options</i> .
Fault Code 02: Hardware fault	There has been a general hardware fault.	Check all equipment and cables for damage.

Fault Code 03: Controller reset	There was a power brownout (a momentary loss of power).	Ensure that no power cables are damaged and check that the connectors are tight. Connect the power directly to the battery.
	The EZ–Steer 500 system controller has reset unexpectedly.	1. Download the error log to a USB Flash Drive. 2. Send the error log to your local reseller.
Fault Code 04: Communication error	The EZ–Steer 500 system controller failed to receive CAN messages from the EZ–Guide 500 lightbar.	1. Check that the cable connection is secure. 2. Check that the cable is not damaged.
Fault Code 05: Bridge fault	The manual override sensitivity is too low.	Increase the <i>Override Sensitivity</i> value from <i>Configuration / Auto Steer / EZ–Steer Setup / Engage Options</i> .
	The controller is faulty.	Contact your local EZ–Steer 500 system reseller for a repair or replacement.
	There is a fault with the vehicle steering or it is too heavy.	Inspect the vehicle's steering components and service them if necessary.
Fault Code 07: Broken motor cable	The motor cable is broken.	Contact your local reseller for a replacement motor cable.
Fault Code 08: EEPROM fault	There was a memory error in the EZ–Steer 500 system controller.	1. Download the error log to a USB Flash Drive. 2. Send the error log to your local reseller.
Fault Code 09: No motor connected	The motor, or motor cable, is not connected to the EZ–Steer system controller.	1. Check that the motor cable is connected to the EZ–Steer 500 system motor. 2. Check that the motor cable is connected to the EZ–Steer 500 system controller. 3. Check that all cable connections are secure and that the cables are not damaged.
Fault Code 10: Unknown fault	There was an unknown fault in the EZ–Steer 500 system.	1. Download the error log to a USB Flash Drive. 2. Send the error log to your local reseller.
Fault Code 11: System fault	The lightbar failed to receive messages from the controller.	1. Check that none of the cables are damaged. 2. Check that the connectors are tight.
		1. Download the error log to a USB Flash Drive. 2. Send the error log to your reseller.
Fault Code 12: EZ–Steer too hot	The controller temperature has exceeded the maximum internal operating temperature of 83 °C (181 °F).	1. Move the controller out of direct sunlight. 2. Ensure that the controller is well ventilated. 3. Turn on the air conditioning and direct the cool air to the controller.

<p>Note – The internal temperature of the controller may be up to 12 °C (22 °F) warmer than the external temperature.</p>		
<p>Fault Code 13: EZ–Steer Over voltage</p>	<p>The power supply to the controller exceeded 12.5 V.</p>	<p>Ensure that you only connect the EZ–Steer 500 system to a 12 V power supply.</p> <p>If you jump start a vehicle with a flat battery, unplug the EZ–Steer 500 system power plug first.</p>
<p>Fault Code 15: T2 Fault</p>	<p>The steering control module (SCM) is loaded with an incompatible version of firmware.</p>	<p>Check with your local reseller what the latest version of the firmware is. Go to <i>Configuration / Status / EZ–Steer Status</i> and check the firmware version displayed. If you do not have the latest version of the firmware on your controller, update it.</p>
	<p>There are low voltage or intermittent problems with the system’s power supply.</p>	<ol style="list-style-type: none"> 1. Check that there are no loose or corroded power connections, especially in the accessory plug area. 2. If necessary, modify the power cable with an in–line fuse and hardware to a reliable power connection. 3. Ensure that the vehicle electrical system is in working order and supplies enough voltage to the system.

Maintenance

Maintenance Schedule

To ensure that your EZ–Steer 500 system continues to operate correctly, follow this maintenance schedule during your vehicle’s regular service or at intervals not exceeding three months:

1. Check that the bolts and nuts that attach the bracket to the steering column are tightened according to the specifications in the steering kit installation instructions.
2. Inspect the vehicle steering column for signs of damage or wear, paying special attention to the areas around the EZ–Steer bracket.
3. Check the position of the EZ–Steer motor relative to the steering wheel and, if necessary, adjust it according to the specifications in the steering kit installation instructions.
4. Check the amount of play in the EZ–Steer motor bearings by gently attempting to move the output shaft from side to side, as well as up and down.
5. Rotate the motor shaft to check there is no noise or resistance in the bearings.
6. Check that the motor mount spring applies sufficient pressure to prevent the foam wheel from slipping on the steering wheel. Replace the spring if necessary.
7. Inspect all cables for damage and replace them if necessary.
8. Check the foam wheel is secure and not excessively worn.
 - a. Remove the plastic plug from the end of the foam wheel.



- b. Make sure that the two screws that hold the wheel to the output shaft are tight.

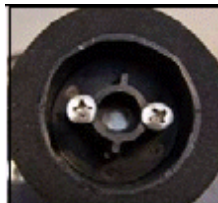

- c. Inspect the foam wheel. If the foam wheel shows signs of excessive wear, flat spots, or deep grooves, replace it.
 - d. Reinstall the plastic plug in the end of the foam wheel.
9. Ensure that the:
 - ◆ EZ–Steer controller is securely fastened to its mounting point
 - ◆ EZ–Steer controller does not show any signs of physical damage
 - ◆ EZ–Steer cables are firmly attached

Pivot Bearing Maintenance

The pivot bearing is lubricated at the factory and should not require maintenance. However, if the steering motor becomes difficult to move from the unlatched to latched position or if there appears to be excessive play in the pivot bearing, follow this procedure to inspect, lubricate, or replace the pivot bearing as necessary:

1. Ensure that the unit is in its unlatched position.
2. Remove the motor mount assembly from the steering column bracket.
3. Remove the shroud:
 - a. With a sharp hobby knife or razor blade, slit the “EZ-Steer” label on the front of the motor down the middle where the two shroud halves join.



- b. With a sharp hobby knife or razor blade, slit the part number / serial number label on the angled surface on the rear of the unit.



Note – You do not need to cut the orange warning label.

- c. Remove the four screws that hold the shroud to the upper mount.



- d. Open the shroud by bending the orange warning label.



e. Remove the shroud.

4. A ¼" screw at the center of the shaft holds the upper mount assembly to the lower mount. Loosen the screw until the screw is almost completely removed.
5. Push the screw head until the shaft and upper mount assembly start to come away from the lower mount. (There will be some resistance due to the spring force.) Push the upper mount assembly away until the screw prevents it coming all the way out. The face of the bearing and some of the shaft will now be visible between the upper and lower mounts.
6. Apply some molybdenum sulphide grease or black grease to the exposed shaft and bearing face.

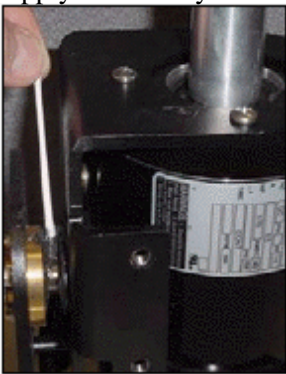

7. Push the two halves back together and pull them apart again. Do this several times, to spread the grease.
8. Tighten the ¼" screw to 5.6 Nm–6.7 Nm (50 in/lb–60 in/lb).
9. Hinge the motor until it latches a few times to spread the grease around the bearing.
10. Ensure that the two grub screws on the steering motor output shaft are tightened to 2.8 Nm–3.4 Nm (25 in/lb–30 in/lb).



11. Re-attach the shroud:
 - a. Ensure that the tongue and groove joint is correctly mated.
 - b. Tighten the four shroud screws to 2.6 Nm–3.0 Nm (23 in/lb–27 in/lb).

Note – Do not over-tighten the shroud screws or you may damage the plastic shroud.
12. Re-attach the motor drive unit to the steering column bracket.

If you notice any damage while carrying out the above maintenance, correct the problem before using the EZ–Steer 500 system. If you are unsure whether or not your EZ–Steer 500 system is in safe working order, contact your local EZ–Steer 500 reseller for assistance.

Appendix A

Introduction

CAUTION – This manual relates to the EZ–Steer system when used with the EZ–Guide 500 system. It should not be used with the EZ–Guide Plus system. If your EZ–Steer system is connected to an EZ–Guide Plus system, refer to the *EZ–Steer System for the EZ–Guide Plus Lightbar Reference Guide*.

Vehicle Speed Limits

The minimum and maximum allowable speed for assisted steering on straight swaths and pivots, based on the selected vehicle type, is:

VEHICLE TYPE	MINIMUM ALLOWABLE SPEED	MAXIMUM ALLOWABLE SPEED
Tractor (2WD)	2 km/h (1 mph)	24 km/h (15 mph)
Tractor (4WD)	2 km/h (1 mph)	24 km/h (15 mph)
Tracked tractor	2 km/h (1 mph)	24 km/h (15 mph)
Combine	2 km/h (1 mph)	24 km/h (15 mph)
Sprayer	2 km/h (1 mph)	32 km/h (20 mph)
Truck	2 km/h (1 mph)	40 km/h (25 mph)
Floater	2 km/h (1 mph)	40 km/h (25 mph)
Swather / Windrower	2 km/h (1 mph)	24 km/h (15 mph)

Note – The speed limit on curved swaths (including curves and headlands) is 19.3 km/h (12 mph) regardless of vehicle type.

Operating Limits

- The maximum internal operating temperature is 83 °C (181 °F).

If the controller reaches this point, it will automatically shut down to avoid damage. To view the current internal temperature of the controller, select *Status / EZ–Steer Status*.

Note – The internal temperature of the controller may be up to 12 °C (22 °F) warmer than the external temperature.

- The maximum operating voltage is 16 VDC. At this point, a warning is displayed and the system is automatically shut down.

CAUTION – Do not supply voltages greater than 16 VDC to the EZ–Steer system, or you risk permanently damaging it.